



User Manual

for S6 Series Hybrid Inverter



Applicable models

S6-EH3P60K10-LV-YD-H

S6-EH3P75K10-LV-YD-H

S6-EH3P80K10-NV-YD-H

S6-EH3P99.9K10-NV-YD-H

S6-EH3P100K10-NV-YD-H

S6-EH3P125K10-NV-YD-H

S6-EH3P75K10-NV-YD-H

S6-EH3P75K10-NV-YD-H-PRO

Applicable System

Three phase system

Important Notes

- Due to the product development, the product specifications and functions are subject to change. The latest manual can be acquired via <https://www.ginlong.com/global>. Every attempt has been made to make this document complete, accurate and up-to-date. Individuals reviewing this document and installers or service personnel are cautioned, however, that Solis reserves the right to make changes without notice and shall not be responsible for any damages, including indirect, incidental or consequential damages caused by reliance on the material presented including, but not limited to, omissions, typographical errors, arithmetical errors or listing errors in the material provided in this document.
- Solis accepts no liability for customers' failure to comply with the instructions for correct installation and will not be held responsible for upstream or downstream systems Solis equipment has supplied.
- Please notice: The system installed as required by Solis, the warranty is only effective for Solis inverter, and other accessories are not guaranteed by Solis warranty.
- The customer is fully liable for any modifications made to the system; therefore, any hardware or software modification, manipulation, or alteration not expressly approved by the manufacturer shall result in the immediate cancellation of the warranty.
- Given the countless possible system configurations and installation environments, it is essential to verify adherence to the following:
 - There is sufficient space suitable for housing the equipment.
 - Airborne noise produced depending on the environment.
 - Potential flammability hazards.
 - Solis will not be held liable for defects or malfunctions arising from:
 - Improper use of the equipment.
 - Deterioration resulting from transportation or particular environmental conditions.
 - Performing maintenance incorrectly or not at all.
 - Tampering or unsafe repairs.
 - Use or installation by unqualified persons.
 - This product contains lethal voltages and should be installed by qualified electrical or service personnel having experience with lethal voltages.

Contents

1. Introduction	01-10
1.1 Product Overview	01
1.2 Inverter Wire Box and Connection Points	06
1.3 Packaging	07
1.4 Tools Required for Installation	07
1.5 Cable and terminal requirements	09
1.6 External breaker and RCD for single unit	10
2. Safety & Warning	11-14
2.1 Safety	11
2.2 General Safety Instructions	12
2.3 Notice for Use	14
2.4 Notice for Disposal	14
2.5 Notice for Transportation	14
3. Installation	15-44
3.1 Select a Location to Install the Inverter	15
3.2 Preparations before lifting	17
3.3 Lifting installation	18
3.4 Product Handling	19
3.5 Mounting the Inverter	20
3.6 Post mounting	22
3.7 Ground Cable Installation	23
3.8 PV Cable Installation	24
3.9 Battery Cable Installation	27
3.10 AC Wiring	32
3.11 Meter/CT Connection	35
3.12 Inverter Communication	37
3.13 Inverter Remote Monitoring Connection	44
4. Overview	45-48
4.1 HMI Screen	45
4.2 HMI screen operation system overview	46
4.3 APP Local debugging interface structure	47
4.4 Inverter built-in Bluetooth description	48

Contents

5. Commissioning	49-57
5.1 Pre-Commissioning	49
5.2 Power ON	49
5.3 Power OFF	49
5.4 HMI Screen Setting	50
5.5 APP Setting	57
6. Maintenance	74
6.1 Smart O&M	74
7. Feature Introduction	75-90
7.1 Storage mode description	75
7.2 Time Of Use	81
7.3 AC coupling system	82
7.4 Generator integrated system	86
7.5 Parallel system	90
8. Troubleshooting	95
8. Specifications	100
9. Appendix - FAQs	115

1.1 Product Overview

The Solis series is designed for commercial hybrid systems.

The inverter can work with maximize self-consumption and provide backup power if the grid fails and there is not enough PV power to cover load demand.

The Solis S6 series consists of the following inverter models:

S6-EH3P60K10-LV-YD-H (Only available for LV grid)

S6-EH3P75K10-LV-YD-H (Only available for LV grid)

S6-EH3P80K10-NV-YD-H

S6-EH3P99.9K10-NV-YD-H (Only available for specific countries in demand)

S6-EH3P100K10-NV-YD-H

S6-EH3P125K10-NV-YD-H

S6-EH3P75K10-NV-YD-H (Only available for Brazil)

S6-EH3P75K10-NV-YD-H-PRO (Only available for Brazil)

S6-EH3P(75-125)K10-NV-YD-H

1 2 3 4 5 6 7 8

Model description

Item	Description
1	The sixth generation
2	E:energy H:Hybrid; A hybrid power system that integrates PV, battery energy storage, and grid to provide stable, efficient and reliable power supply.
3	Three phase
4	Rated output Power of Hybrid
5	10 MPPTS
6	Grid Voltage Normal(220 V / 380 V,230 V / 400 V)
7	LCD Screen
8	Compatible with high-voltage batteries

* LV means LV grid(127V / 220V, 133V / 230V)



NOTE

Solis AFCI 2.0 Function meets the INMETRO Ordinance No.515 regulation. This product supports AFCI2.0 function as an optional function for customers. By default the AFCI function is not supported.



NOTE

Only on Brazil and Chile market are sold with AFCI2.0 as default configuration. If you want to use it, please refer to the manual to enable the AFCI function.

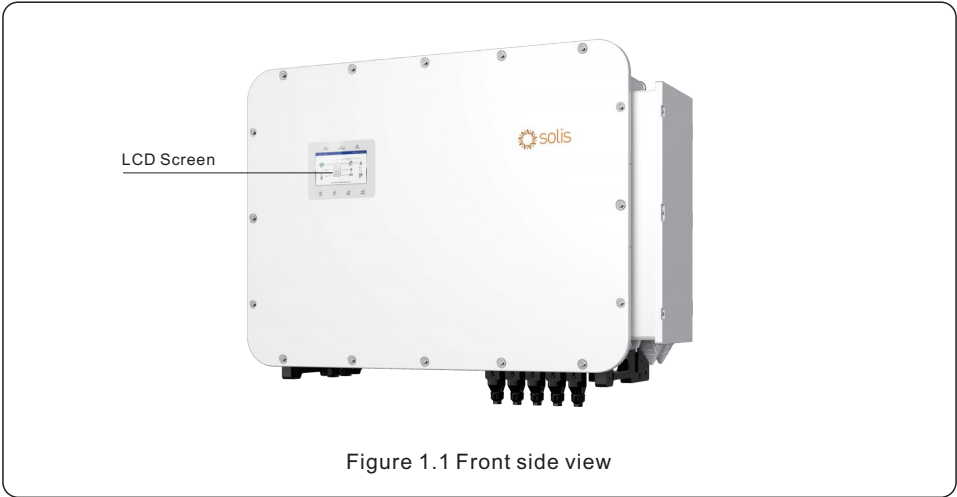

This inverter is suitable for the three-phase grid systems as below (according to IEC 60364)

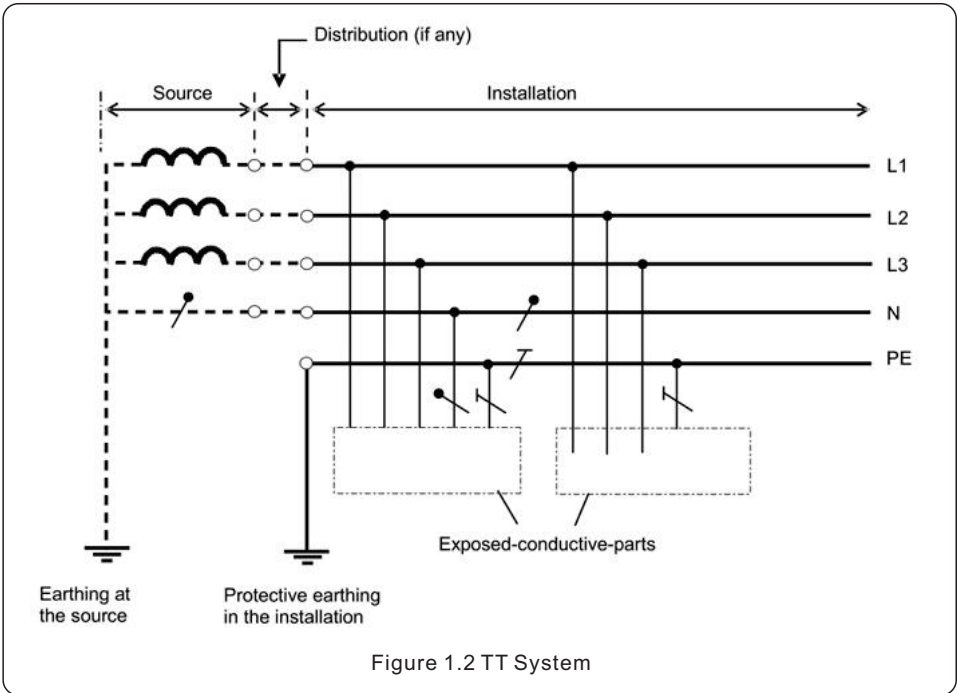

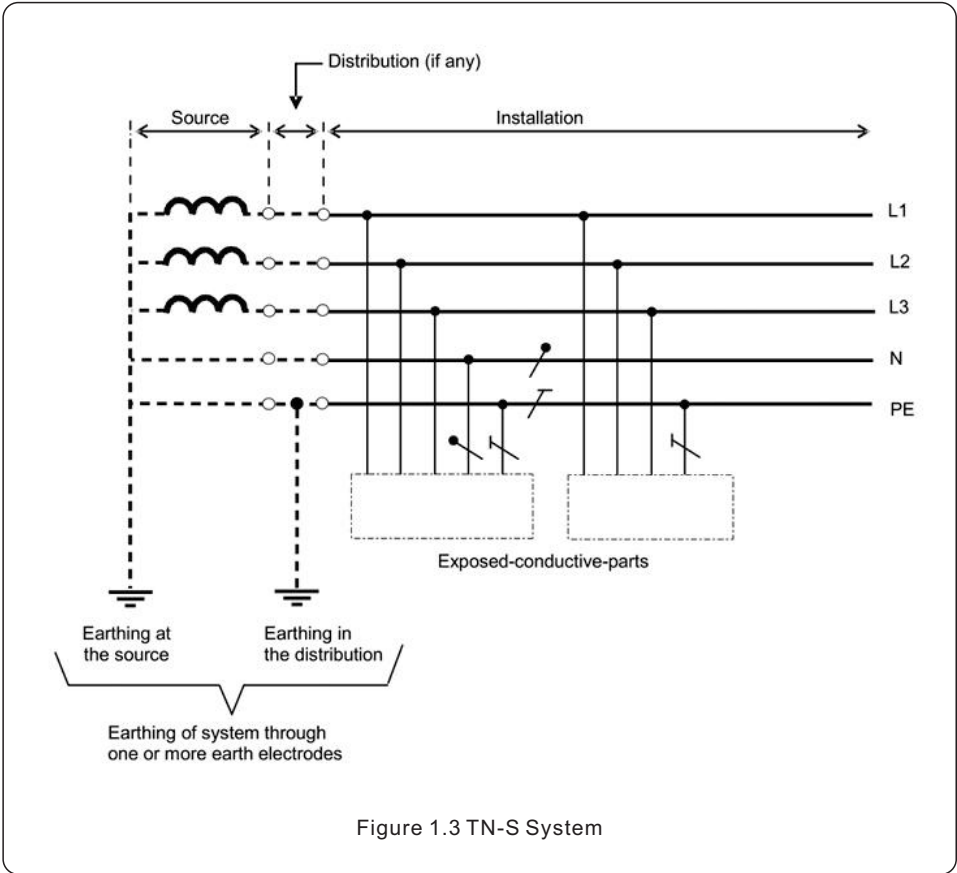

Figure 1.3 TN-S System

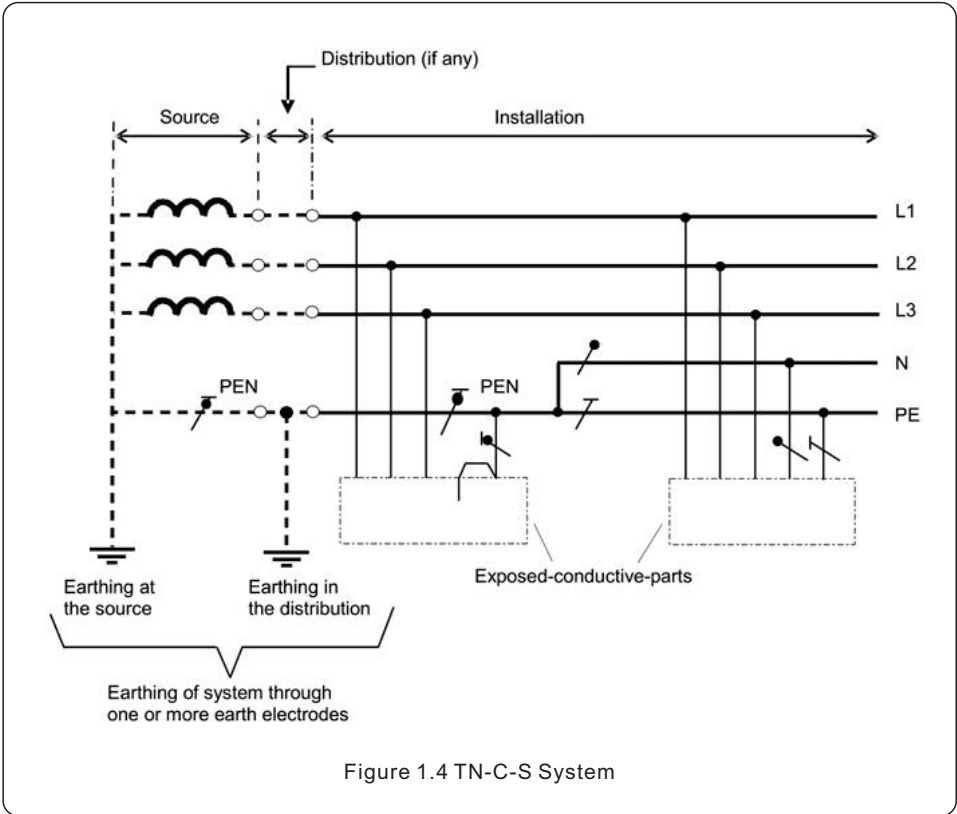

Figure 1.4 TN-C-S System

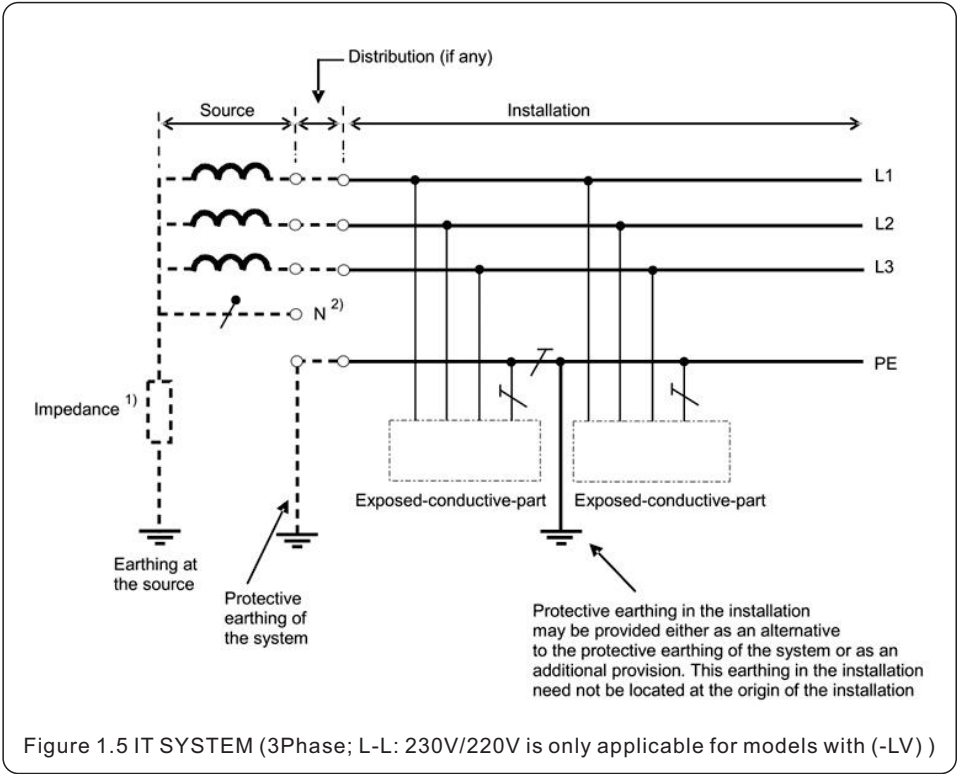

Figure 1.5 IT SYSTEM (3Phase; L-L: 230V/220V is only applicable for models with (-LV))

1.2 Inverter Wire Box and Connection Points

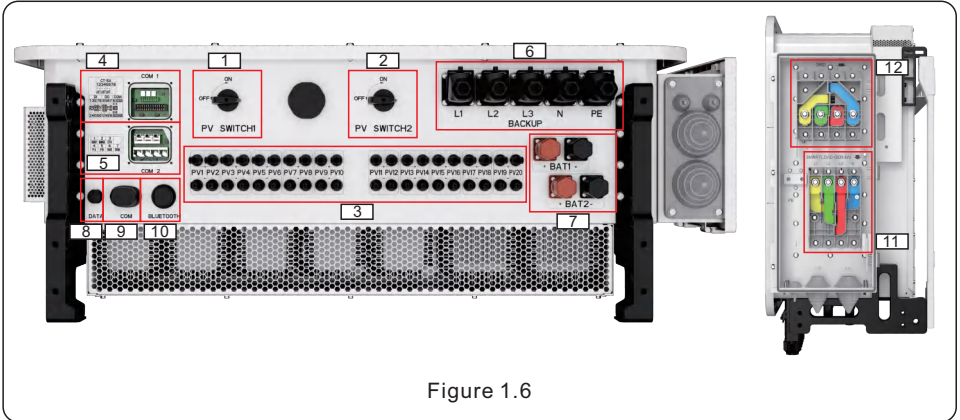

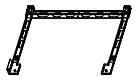







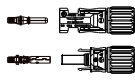



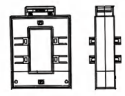









Figure 1.6

Name	Description
1. PV Switch1	PV switch of the PV1- Pv10
2. PV Switch2	PV switch of the PV11- Pv20
3. PV Module Input	Conduit of PV conductors should be connected here
4. COM1	Communication cables of terminal block should go through this port
5. COM2	Communication cables of terminal block should go through this port
6. BACKUP	Conduit of AC conductors to backup loads panel should be connected here
7. Battery Connection	Conduit of Battery conductors should be connected here
8. DATA	For hybrid inverter communication signal enhancement, no need operation
9. COM	For Solis data logger connection
10. BlueTooth	A antenna for Bluetooth signal.no need operation
11. SMARTLOAD/GEN/INV	Conduit of AC conductors to generator should be connected here
12. Grid	Conduit of AC conductors to the main service panel should be connected here

1.3 Packaging

Please ensure that the following items are included in the packaging with your machine:

 Inverter x1	 Back plate x1	 Hex Head Bolt Assembly M10*40 x4	 Flat Washer Φ 10 (C Grade Flat Washer) x4	 Hex Nut M10 x4	 Phillips Cross Recess Hex Head Bolt Assembly M10*20 x8
 Expansion Bolt M10*70 x4	 Phillips recess hex head combination screw M8*20 x2	 RJ45 connector x10	 DC connector x20	 Through-wall terminal wiring cover x5	 Through-wall Terminal Cover (Black) x2
 Through-wall Terminal Cover (Orange) x2	 Handle x4	 CT x3	 CT cables x1	 Dual RJ45 Plug Shielded Cable Harness - 5000mm x1	 Eastron Meter (optional) x1
 Lifting Buckle x2	 L type spanner x1	 S2-WL-ST Data logger x1	 Quick Installation Manual x1		

If anything is missing, please contact your local Solis distributor.

1.4 Tools Required for Installation

Please notice, the following tools need to be prepared by customers.

 1	 2	 3	 4	 5	 6
 7	 8	 9	 10	 11	 12
 13	 14	 15	 16	 17	 18-20

NO.	Tool category	Tool name	Spec & No.	Function
1	Lifting tool	lift belt	500kg * 2	For inverter lifting
2		Buckle hook	500kg * 2	For inverter lifting, used in conjunction with lift belt
3	Installation	Impact drill	FM10	For M10 expansion bolt
4	Wire-making tool	Wire Strippers	12AWG to 6AWG	Stripping PV cables
5		Wire Strippers	20AWG to 10AWG	Stripping communication cables
6		LUG Crimping Tool	4AWG to 2/0AWG	For smart port / grid / battery cables
7		Wire cutter	4AWG to 2/0AWG	For smart port / grid / battery cables
8		Ethernet crimper	/	Crimping Ethernet cable
9		Crimper	MC4	Crimping MC4 PV connector and communication cable
10	Wiring tool	Technician Screwdriver	Φ3mm	For communication cable wiring
11		Screwdriver	Torqx T20	For communication cable wiring
12		Multi-bit screwdriver	/	For communication cable wiring
13		Electric Screwdriver	/	For installing or removing) screws
14		Socket/Bolt Wrench Tool (*)	Socket Sizes: 8 mm – 19 mm External Bolt Sizes: M8, M10, M12	For smart port / grid / battery cables (*)
15	Battery wiring (Choose either)	90-Degree Screwdriver (recommended)	T27(M6)	For battery cable wiring
16		hex key	T27, L>115mm	For battery cable wiring
17	Testing tool	Multimeter (AC/DC amps)	/	For measuring AC/DC amps
18	OT terminal	M6 OT terminal	M6 * 4	For battery wiring
19		M12 OT terminal	M12 * 8	For smart port & Grid wiring
20		M10 OT terminal	M10 * 3	For PE wiring



NOTE

When using a socket tool to wire Backup terminals, a 1/2" ratchet wrench may scratch the top cover, recommend spec as follows (choose either):

- 3/8" ratchet wrench + extension bar (>100mm)
- 1/4" ratchet wrench + extension bar (>100mm)

1.5 Cable and terminal requirements

Terminal type	Battery	Backup	Smart port	Grid	PE
Recommend copper cable diameter	25-35mm ²	70mm ²	70mm ²	95mm ²	50-70mm ²
Max. cable diameter	35mm ²	95mm ²	120mm ²	150mm ²	70mm ²
OT terminal	M6	M8	M12	M12	M10
Quantity	4	5	4	4	3
Cable Lug	RNB38-6/6S SC35-6	70/95-8	70/95/120-12	95/120/150-12	50/70-10
Torque	4-5N.m	10-12N.m	20-30N.m	20-30N.m	10-20N.m
Aluminum Cable Connection Support	NO	YES (max. 95 mm ²)	YES	YES	YES



NOTE

1. Backup OT terminals suitable for 70mm² cable, if customer use other size cables, please prepare corresponding OT terminals.
2. Copper cable recommended, backup port cannot export full power with aluminum cable. If customer has to wiring aluminum cable, needs copper-to-aluminum connector for AC wiring.

1.6 External breaker and RCD for single unit

Item	Backup/Smart Port Breaker		Grid Port Breaker		External RCD	Recommended Fuse (Battery)	Recommended Breaker (Battery)
	60K/75K	(75-125)K	60K/75K	(75-125)K			
Rated Voltage (Ue)	≥ 230 Vac	≥ 400 Vac	≥ 230 Vac	≥ 400 Vac	—	≥ 1000 Vac	≥ 1000 Vac
Rated Current (In)	≥ 200 A (60kW) ≥ 250 A (75kW)	> 225 A	≥ 315 A	≥ 315 A	—	≥ 150 A	≥ 125 A
Short-Circuit Capacity (Ics / Breaking Capacity)	≥ AC 50 kA	≥ AC 50 kA	≥ AC 50 kA	≥ AC 50 kA	—	≥ DC 50 kA	≥ DC 50 kA
Altitude	0-2500 m (no derating)	0-2500 m (no derating)	0-2500 m (no derating)	0-2500 m (no derating)	—	0-2000 m (no derating)	0-2500 m (no derating)
Temperature	-35°C ~ 40°C (no freq reduction)	-35°C ~ 40°C (no freq reduction)	-35°C ~ 40°C (no freq reduction)	-35°C ~ 40°C (no freq reduction)	—	-5°C ~ 40°C (no derating)	-40°C ~ 55°C (no derating)
Residual Current (IΔn)	—	—	—	—	≥ 500 mA	—	—
Instantaneous Trip Current (Ii)	—	—	—	—	—	—	≥ 625 A

For parallel system, Please note:

1. The rated current (In) / Residual Current (IΔn) * N (where N is the number of units in parallel)
2. RCD should be installed at the busbar, not at individual backup ports.

2.1 Safety

The following types of safety instructions and general information appear in this document as described below:



DANGER

“Danger” indicates a hazardous situation which if not avoided, will result in death or serious injury.



WARNING

“Warning” indicates a hazardous situation which if not avoided, could result in death or serious injury.



CAUTION

“Caution” indicates a hazardous situation which if not avoided, could result in minor or moderate injury.



NOTE

“Note” provides tips that are valuable for the optimal operation of your product.



WARNING: Risk of fire

Despite careful construction, electrical devices can cause fires.

- Do not install the inverter in an area containing flammable materials or gases.
- Do not install the inverter in a potentially explosive atmosphere.



WARNING

Only professional lifting personnel are allowed to operate. Safety helmets, anti-slip gloves and other protective equipment must be worn.

Before lifting, check that the lifting gear (wire ropes, slings, shackles, etc.) are free from wear, rust or deformation.

Ensure that there are no unauthorized personnel in the operation area, and the ground is flat and stable to avoid tilting or shaking.

2.2 General Safety Instructions



WARNING

Only devices in compliance with SELV (EN 69050) may be connected to the RS485 and USB interfaces.



WARNING

Do not connect PV array positive (+) or negative (-) to ground, doing so could cause serious damage to the inverter.



WARNING

Electrical installations must be done in accordance with local and national electrical safety standards.



WARNING

Do not touch any internal parts until 5 minutes after disconnection from the utility grid, PV array, and battery.



WARNING

To reduce the risk of fire, over-current protective devices (OCPD) are required for all circuits connected to the inverter.

The DC OCPD shall be installed per local requirements. All photovoltaic source and output circuit conductors shall have isolators that comply with the NEC Article 690, Part II.

All Solis three phase inverters feature an integrated DC disconnect switch.



CAUTION

Risk of electric shock, do not remove the cover. There are no serviceable parts inside, refer servicing to qualified and accredited service technicians.



CAUTION

The PV conductors are energized with high voltage DC when the PV modules are exposed to sunlight.



CAUTION

The surface temperature of the inverter can reach up to 75°C.

To avoid risk of burns, do not touch the surface of the inverter while it is operating. The inverter must be installed out of direct sunlight exposure.



NOTE

PV modules used with inverter must have an IEC 61730 Class A rating.



WARNING

Operations must be accomplished by a licensed electrician or a person authorized by Solis.



WARNING

Installer must wear personal protective equipment during the entire installation process in case of electrical hazards.



WARNING

The AC Backup Port of the inverter cannot be connected to the grid.



WARNING

Please refer to the product manual of the battery before installation and configuration to the inverter.



NOTE

PV Simulator Power-On Sequence: When using a PV simulator to test the inverter, you must turn on the inverter's PV DC switch first, and then turn on the PV simulator. Failure to follow this sequence will cause equipment damage.



NOTE

PV Simulator Power-Off Sequence: To shut down the system, always turn off the PV simulator first, and then turn off the inverter. Reversing this order may cause equipment failure or a fire hazard on site. or equipment damage.



NOTE

Critical Warning: Do not use a battery to simulate a real PV input for testing under any circumstances. This improper substitution can lead to equipment failure or a fire hazard, or direct equipment damage.



WARNING

Equipment tilts: Slowly descend to the ground and reposition the sling.
Hoist cable breaks: Evacuate personnel promptly and activate the backup hoist.



CAUTION

Single-person operation is prohibited. At least two people are required to cooperate (one person to direct, one person to operate the lifting equipment). During the lifting process, it is strictly forbidden to grip the bottom of the equipment or stand under the suspended object. If any abnormal sounds, deviation or abnormality of the lifting equipment is detected, immediately stop the operation and investigate the cause.



Systems using this product shall be designed and built in accordance with the NEC & local electrical codes & standards.

2.3 Notice for Use

The inverter has been constructed according to the applicable safety and technical guidelines, use the inverter in installations that meet the following specifications only:

1. Permanent installation is required.
2. The electrical installation must be compliant with all local and national regulations & standards.
3. The inverter must be installed according to the instructions stated in this manual.
4. The inverter must be installed according to the inverter technical specifications.

2.4 Notice for Disposal

This product shall not be disposed as household waste.

It must be segregated and brought to an appropriate disposal facility to ensure proper recycling.

This is to be done in order to avoid negative impacts on the environment and human health.

Local waste management rules shall be observed and respected.

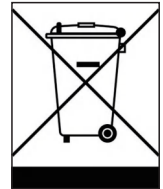

2.5 Notice for Transportation

For the transportation demands of integrating with battery or install inverter in container, solis only support separate transport, and the battery pack should be placed in the freight cabinet follow the battery manufacturer's rule, and the inverter should be placed on its own tray, we also don't support the machine is transported in the cabinet in the form of back-hanging.

3.1 Select a Location to Install the Inverter

When selecting a location for the inverter, the following criteria should be considered:

- Exposure to direct sunlight may cause output power derating due to overheating. It is recommended to avoid installing the inverter in direct sunlight. The ideal location is one where the ambient temperature does not exceed 40°C.
- It is also recommended to install the inverter somewhere the rain and snow will not land directly on it. The ideal installation location is on a north-facing wall under an eave.

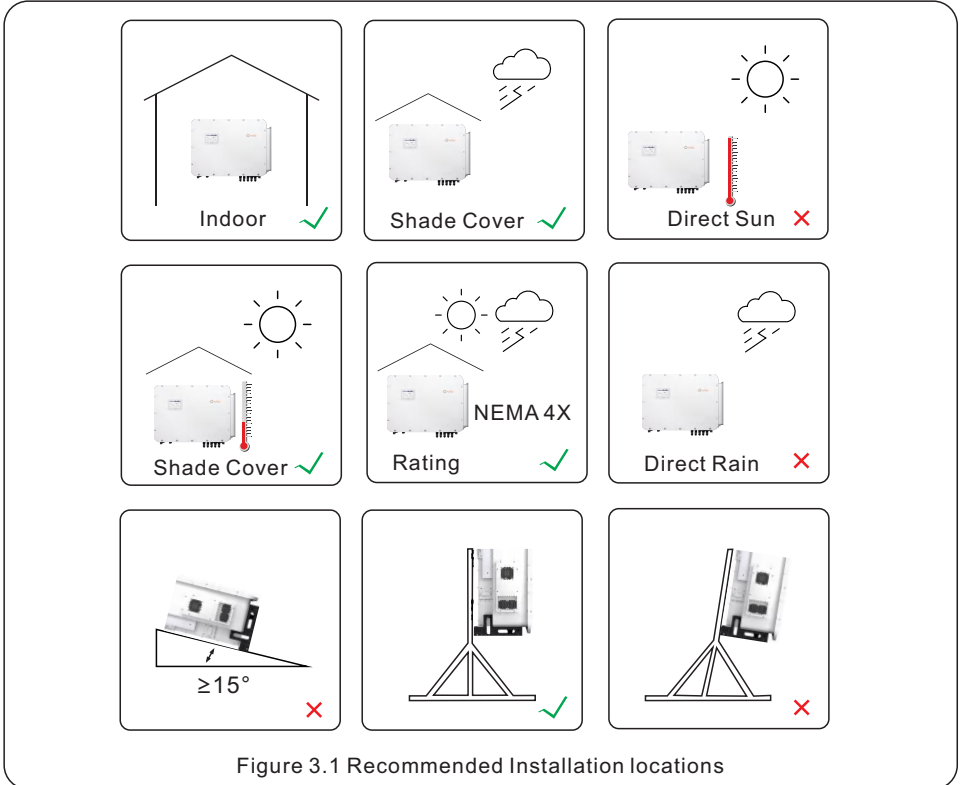

WARNING: Risk of fire



Despite careful construction, electrical devices can cause fires.

- Do not install the inverter in areas containing highly flammable materials or gases.
- Do not install the inverter in potentially explosive atmospheres.
- The mounting structure where the inverter is installed must be fireproof.

When selecting a location for the inverter, consider the following:



CAUTION: Hot Surface

- The temperature of the inverter heat-sink can reach 75°C.

The ambient temperature and relative humidity of the installation environment should meet the following requirements:



Max: +60°C

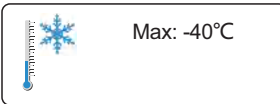

Max: -40°C

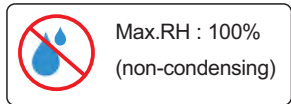

Max.RH : 100%
(non-condensing)

Installation environment conditions



Load bearing surface:

Made of non-inflammable materials



Max. load bearing capacity \geq 4 times of inverter weight.
About the bearing wall. Only supports wall-mounted installation with solid walls.



3.1.1 Clearances

- If multiple inverters are installed on site, a minimum clearance of 800mm should be kept between each inverter and all other mounted equipment. The bottom of the inverter should be at least 400mm above of the ground or floor.
- The LED status indicator lights located on the inverter's front panel should not be blocked
- Adequate ventilation must be present if the inverter is to be installed in a confined space.

3.1.2 Consult technical data

- Consult the technical specifications sections at the end of this manual for additional environmental condition requirements (temperature range, altitude, etc.)

3.1.3 Angle of installation

- This model of Solis inverter must be mounted vertically (90 degrees or backwards less than or equal to 15 degrees from 90 degrees straight up).

3.1.4 Avoiding direct sunlight

Installation of the inverter in a location exposed to direct sunlight should to be avoided.

Direct exposure to sunlight could cause:

- Power output limitation (with a resulting decreased energy production by the system).
- Premature wear of the electrical/electromechanical components.
- Premature wear of the mechanical components (gaskets) and user interface.

3.1.5 Air circulation

Do not install in small, closed rooms where air cannot freely circulate.
To prevent overheating, always ensure that the air flow around the inverter is not blocked.

3.1.6 Flammable substances

Do not install near flammable substances. Maintain a minimum distance of three meters (10 feet) from such substances.

3.1.7 Living area

Do not install in a living area where the prolonged presence of people or animals is expected. Depending on where the inverter is installed (for example: the type of surface around the inverter, the general properties of the room, etc.) and the quality of the electricity supply, the sound level from the inverter can be quite high.

3.2 Preparations before lifting

3.2.1 Equipment inspection

Confirm that the inverter housing is undamaged and that there are no cracks or deformations at the lifting points (such as lifting lugs and brackets).
Check that the weight of the inverter matches the load of the lifting equipment (such as forklifts, cranes) (it is recommended that the lifting capacity of the lifting equipment be twice that of the inverter).

3.2.2 Selection of lifting gear

- It is recommended to use nylon slings (or steel wire ropes) that are 5 to 7 times the weight of the inverter.
- The hook must be equipped with a safety lock to prevent it from coming off.
- It is recommended to use lifting rings with a torque of 12-15N and a rated load of $\geq 200\text{Kg}$.

3.2.3 Lifting steps

- **Fixed lifting gear:**
Symmetrically hang the lifting strap to the inverter lifting point and adjust the Angle by $\geq 60^\circ$ (as shown in the figure).
- **Test lift:**
Slowly lift to 10cm above the ground, check the balance and equipment stability, stay for 1 minute without any abnormalities, and then continue.
- **Smooth movement:**
Maintain a uniform lifting speed. Do not make sudden stops, swing or collide with surrounding objects.
- **Positioning and installation:**
After lowering to the installation base, first fix the bottom bracket, and then release the lifting gear.

3.3 Lifting installation

Description of lifting and installation process and recommended parameters of lifting equipment.

Ear hanging size: M10

Lifting positions as shown in the red box in the following figure (a total of 2 locations)

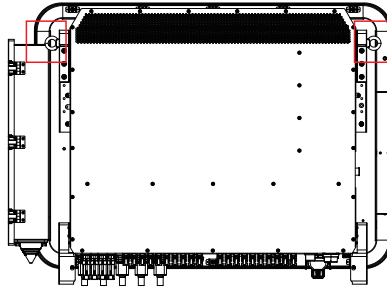

Figure 3.2

There are two common types of lifting, as shown in the following figure. Users can adopt different types of lifting according to specific circumstances. The specific usage requirements are as follows.

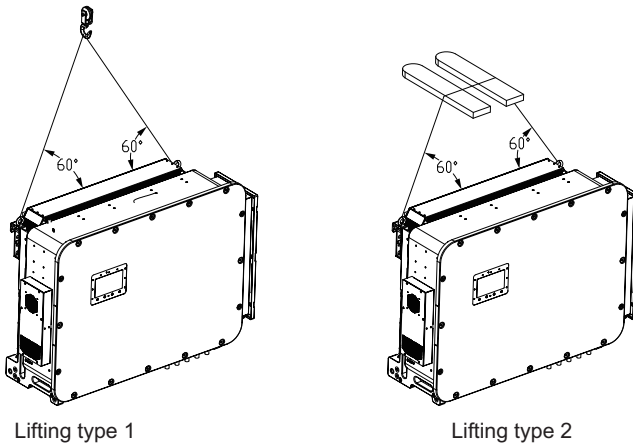

Figure 3.3

3.4 Product Handling

1. After opening the packaging box, stand the inverter upright and place it. When doing this, operate slowly and gently to ensure that the internal components and the casing do not suffer any damage.
2. This machine is equipped with 4 black detachable installation handles. You can choose the appropriate installation position according to your actual needs.
3. The installation positions of the handles are shown in the figure. The red circles represent the 6 installation positions of the handles (on one side), and there are a total of 12 installation positions on both sides. When installing, make sure that the installation positions on both sides are symmetrical.

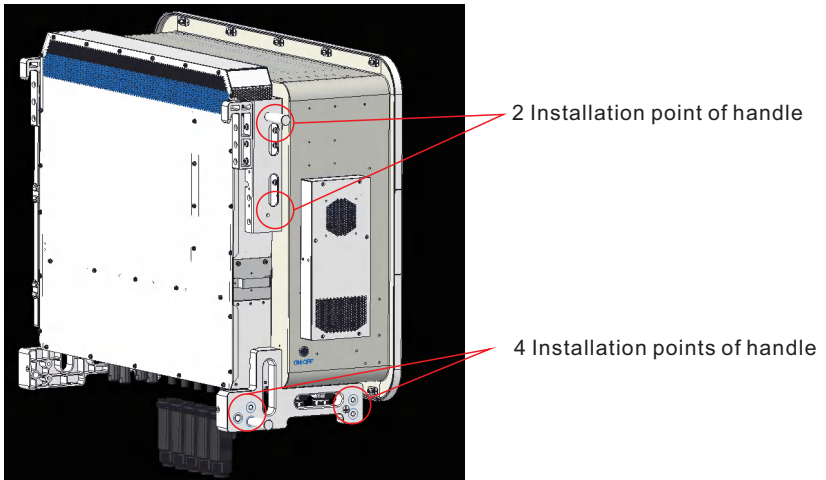

Figure 3.4

3.5 Mounting the Inverter

- Mount the inverter on a wall or structure capable of bearing the weight of the machine.
- The inverter must be mounted vertically with a maximum incline of +/- 5 degree. Exceeding this may cause the output power to derate.
- To avoid overheating, always make sure the flow of air around the inverter is not blocked. For the installation distance, you should refer to the following regulation:
The minimum installation distance from the top is 200mm, 450mm on the left and right, 400mm at the bottom, and 1 meter at the front.



Figure 3.5 Inverter Mounting Clearances

- Visibility of the LED indicator lights should be considered.
- Adequate ventilation around the inverter must be provided.



NOTE

Nothing should be stored on the top of or placed against the inverter.

Dimensions of mounting bracket:

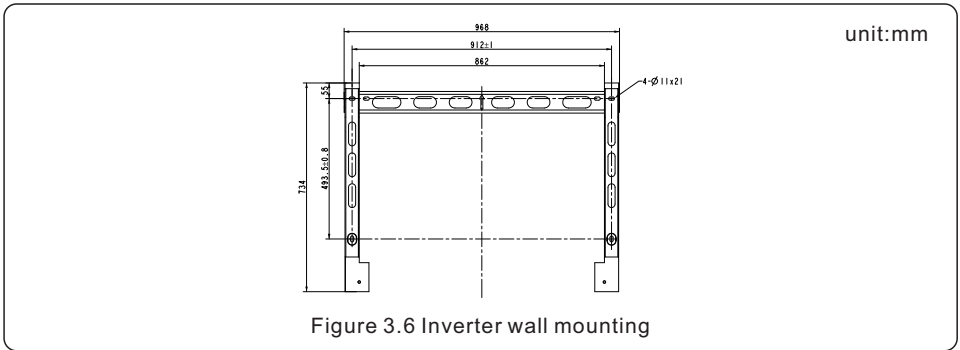

Once a suitable location has been found according to 3.1 using figure 3.6 mount the wall bracket to the wall.

The inverter shall be mounted vertically.

The steps to mount the inverter are listed as below:

1. Select the mounting height of the bracket and mark the mounting holes.
For brick walls, the position of the holes should be suitable for the expansion bolts.
2. Lift up the inverter (be careful to avoid body strain), and align the back bracket on the inverter with the convex section of the mounting bracket. Hang the inverter on the mounting bracket and make sure the inverter is secure (see Figure 3.7)

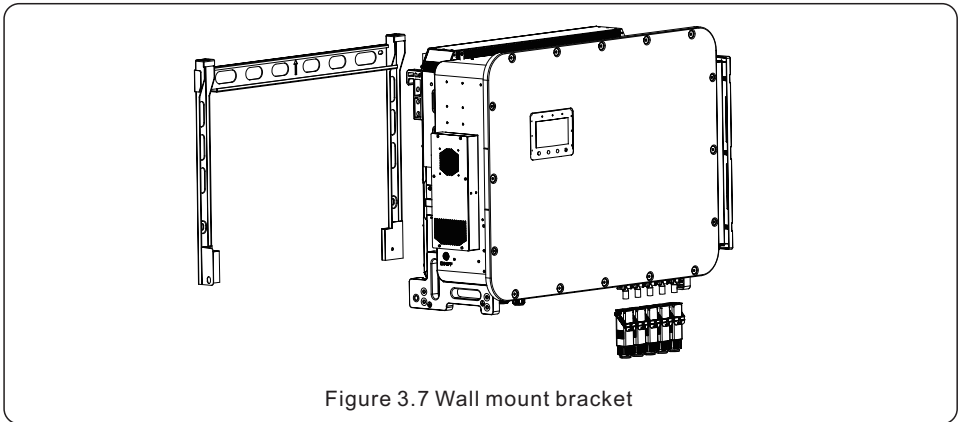

WARNING:

The inverter must be mounted vertically.

3.6 Post mounting

You can also use the post mounting method to install the inverter,

1. The on-site post need to be fixed to the ground through components.
2. When using post mounting, the minimum ground clearance at the bottom of the inverter should be $> 400\text{mm}$.
3. Ensure that the surrounding environment meets the working environment requirements of the inverter.
4. For other installation-related matters, please consult Solis technicians.

Here it's the post mounting example schematic diagram.

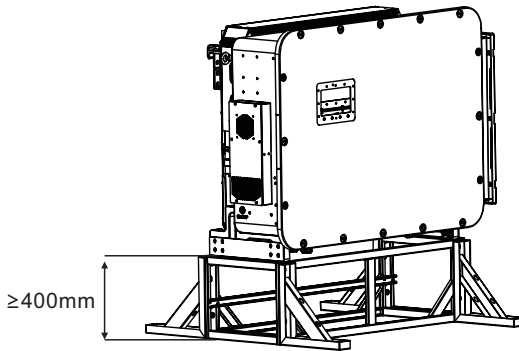

Figure 3.8

3.7 Ground Cable Installation

An external ground connection is provided at the both sides of inverter.

Prepare OT terminals: M10. Use proper tooling to crimp the lug to the terminal.

Connect the OT terminal with ground cable to the right side of inverter. The torque is 10-12N.m.

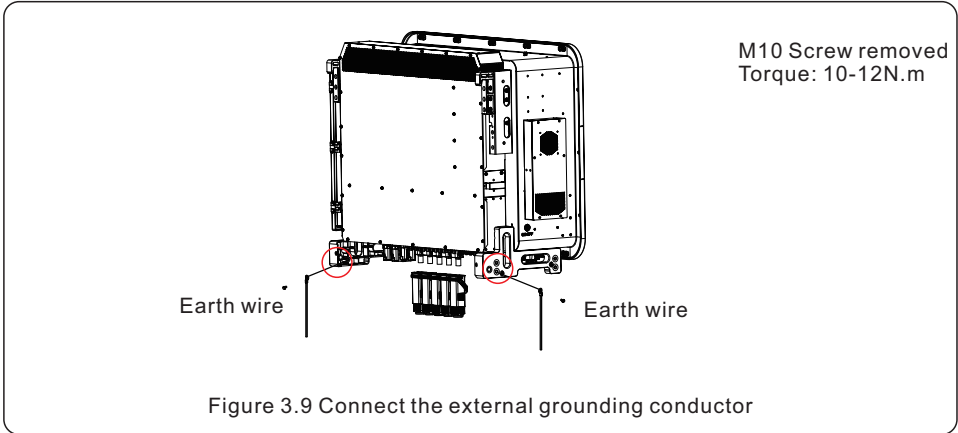

External grounding connection terminals are provided on both sides of the bottom bracket of the inverter. The grounding positions are as shown in the figure, located at the red circles. There are a total of 8 grounding positions on both sides.

Terminal type: OT terminal; Bolt type: M10. Use the appropriate tool to press the wire onto the terminal block.

Connect the OT terminal to both sides of the inverter, with a torque of 10-12 Nm.

To connect the grounding terminal of the bottom bracket, it is recommended to use copper wire. Solis conductors or stranded wires can be used. The specific wire size should refer to local standards and regulations.

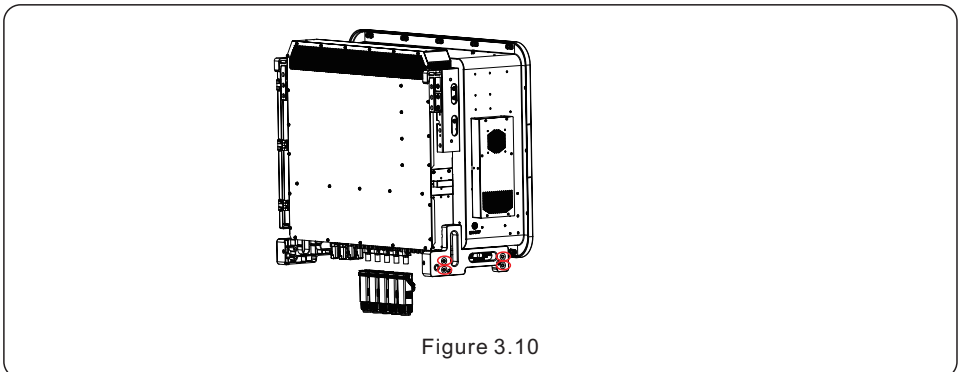

3.8 PV Cable Installation



Before connecting inverter, please make sure the PV array open circuit voltage is within the limit of the inverter.



Before connection, please make sure the polarity of the output voltage of PV array matches the "DC+" and "DC-" symbols.



Please use approved DC cable for PV system.



WARNING:

This series does not support parallel connection after DC-side convergence, and only supports connecting PV strings directly to the inverter.

1. Select a suitable DC cable and strip the wires out by $7\pm 0.5\text{mm}$. Please refer to the table below for specific specifications.

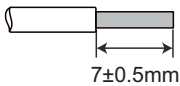

Cable type	Cross section (mm ²)	
	Range	Recommended value
Industry generic PV cable	4.0~6.0 (12~10AWG)	4.0 (12AWG)

Figure 3.11

2. Take the DC terminal out of the accessory bag, turn the screw cap to disassemble it, and take out the waterproof rubber ring.

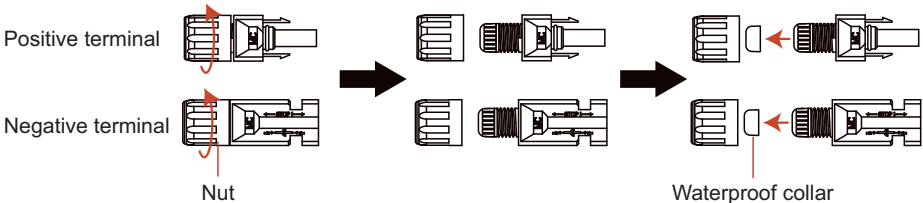
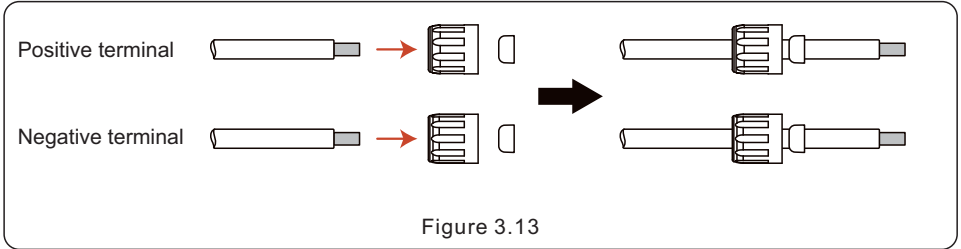
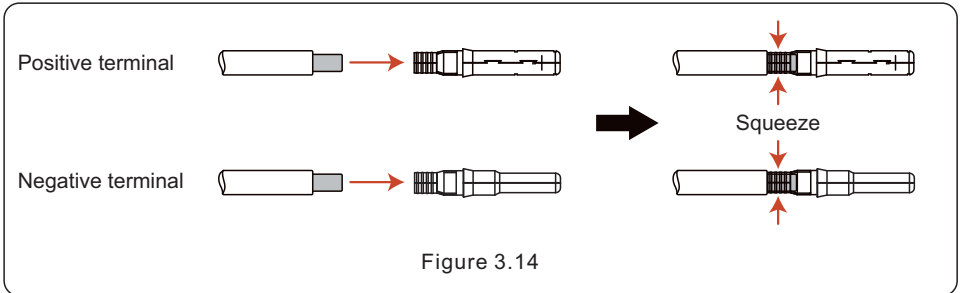

Figure 3.12

3. Pass the stripped DC cable through the nut and waterproof rubber ring.



4. Connect the wire part of the DC cable to the metal DC terminal and crimp it with a special DC terminal crimping tool.



5. Insert the crimped DC cable into the DC terminal firmly, then insert the waterproof rubber ring into the DC terminal and tighten the nut.

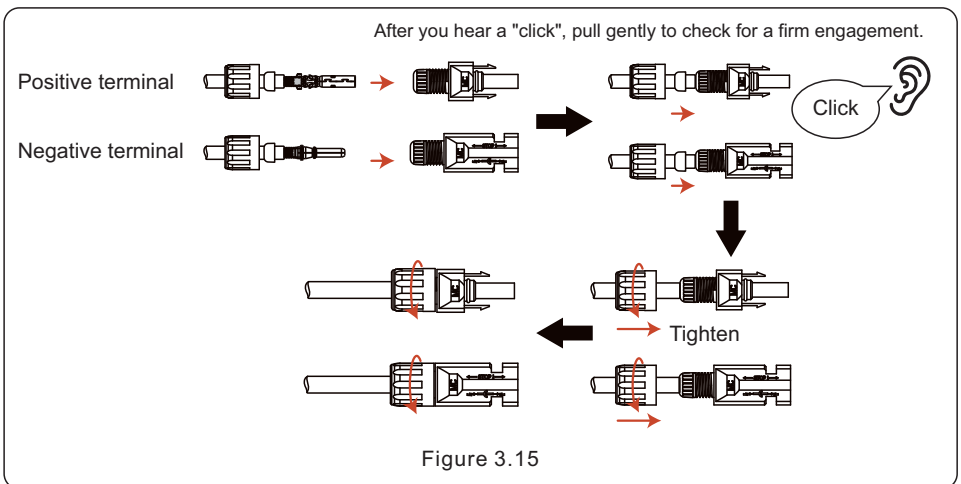

6. Measure PV voltage of DC input with multimeter, verify DC input cable polarity.

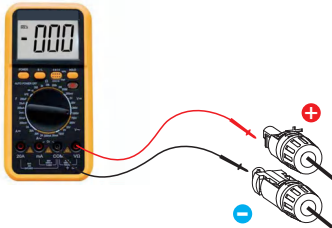

Figure 3.16

7. Connect the wired DC terminal to the inverter as shown in the figure, and a slight "click" is heard to prove the connection is correct.

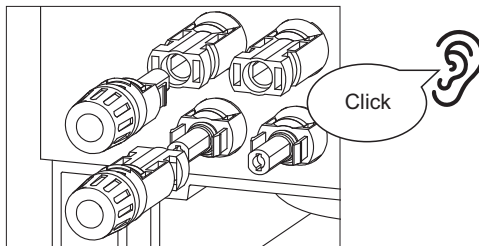

Figure 3.17



CAUTION:

If DC inputs are accidentally reversely connected or inverter is faulty or not working properly, it is NOT allowed to turn off the DC switch. Otherwise it may cause DC arc and damage the inverter or even lead to a fire disaster. The correct actions are:

- *Use a clip-on ammeter to measure the DC string current.

- *If it is above 0.5A, please wait for the solar irradiance reduces until the current decreases to below 0.5A.

- *Only after the current is below 0.5A, you are allowed to turn off the DC switches and disconnect the PV strings.

- * In order to completely eliminate the possibility of failure, please disconnect the PV strings after turning off the DC switch to avoid secondary failures due to continuous PV energy on the next day.

Please note that any damages due to wrong operations are not covered in the device warranty.

3.9 Battery Cable Installation



DANGER

Before installing the battery cables, be sure that the battery is turned off. Use a multimeter to verify that the battery voltage is 0Vdc before proceeding. Consult the battery product manual for instructions on how to turn it off.

3.9.1 Battery wiring method

Inverter supports the 3 wiring methods to connect to lithium battery.

If you have only one battery, you **MUST** connect it to BAT 1 port on inverter, and communication cable **MUST** be connected to BMS 1 port on the inside terminal block.

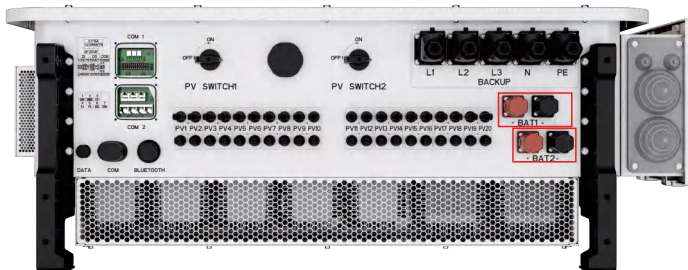

Figure 3.18 Battery connection ports(For Power Cables)

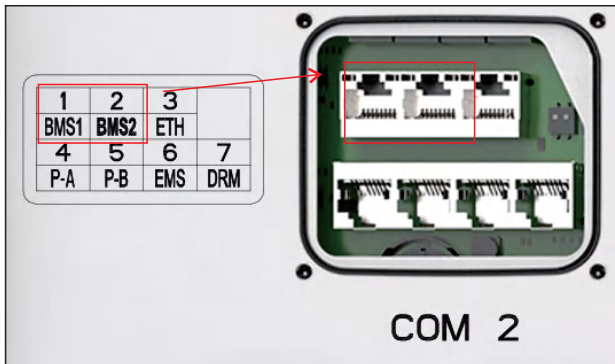
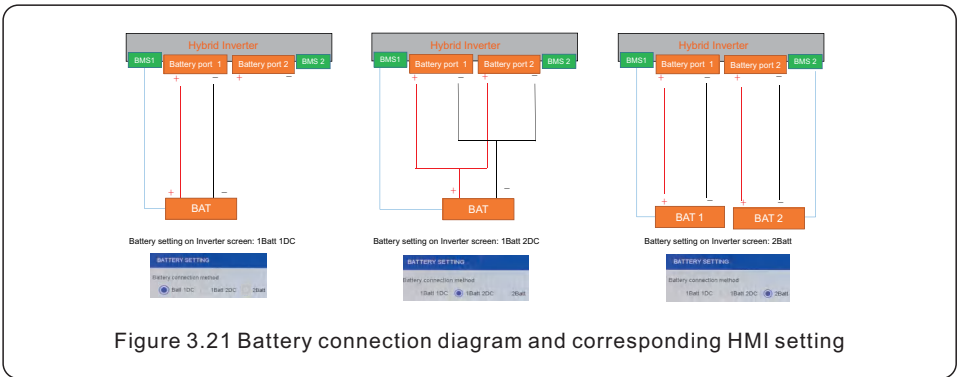
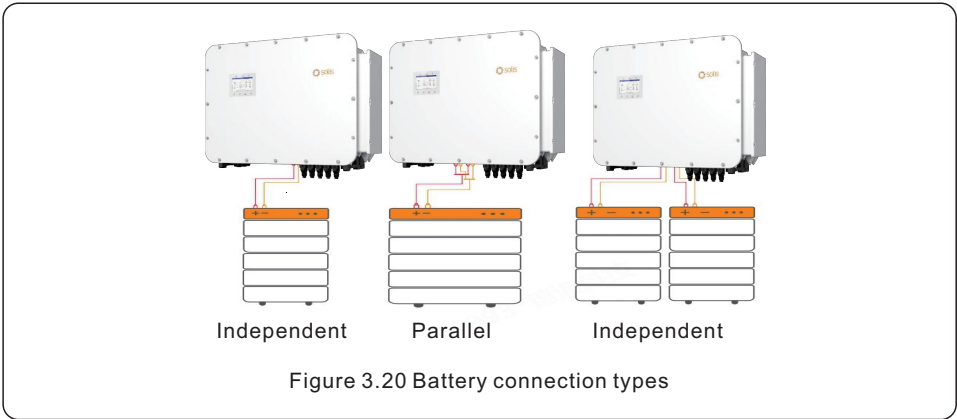

Figure 3.19 Battery connection ports(For Communication cables)



3.9.2 Battery cable connection

Recommended battery fuse, breaker, cable spec refer to chapter 1.5 & 1.6.

1. Insert the lock into the terminal socket and remove the protective cover.

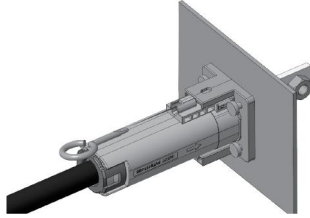

Figure 3.22

2. Insert the lock into the terminal socket and remove the protective cover.



Figure 3.23

(1) Pass the cable sequentially through the end cap, tail sealing ring, and waterproof housing before crimping the cable lug.

(2) After passing the protective cover over the cable, strip the cable's outer sheath and insulation layer, then press or solder it onto the terminal (crimping reference is as shown below).

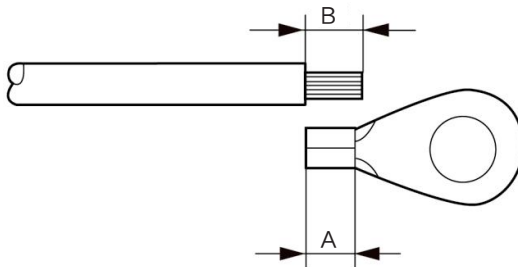

Figure 3.24



NOTE

B (insulation stripping length) is 2mm - 3mm longer than A (OT cable terminal crimping area).

(3)After inserting the cable, press the cable sealing ring into the fixed position and secure the end cap.

3. Secure the terminal.

Use a hex wrench to tighten the screw (4.5–5.0 N·m).

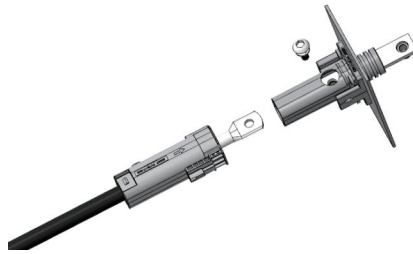

Figure 3.25

4. Engage the protective cover.

Adjust the plug to align with the bottom of the socket, then push it forward. An audible click will indicate when the side clips are fully engaged. While pushing the protective cover, ensure the side rails are aligned, otherwise proper engagement may not be achieved.

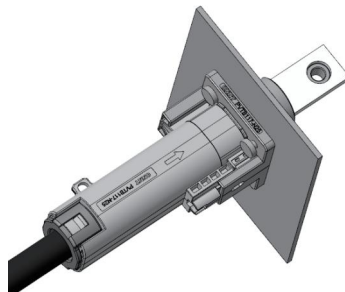

Figure 3.26

3.9.3 Battery voltage-current curve



NOTE:

1. Two battery port has to be used for fully charging; Max. Charge/discharge current of single battery port is 100A; Single channel charge/discharge can reach to 65 kW, two channel can reach to 130kW in total (125K as example);
2. For fully charging, we recommend that the battery voltage should be > 600V; When battery voltage < 400V, battery charge/discharge will be limited as following table.

S6-EH3P(75-125)K10-NV-YD-H			
NO.	Battery voltage(V)	Battery Current(A)	Battery Power(KW)
1	150	70	10.5
2	200	80	16
3	300	90	27
4	400	100	40
5	500	100	50
6	550	100	55
7	600	100	60
8	700	93	65
9	800	81	65
10	900	72	65
11	950	68	65



NOTE:

The above table are only for single battery port.

3.10 AC Wiring

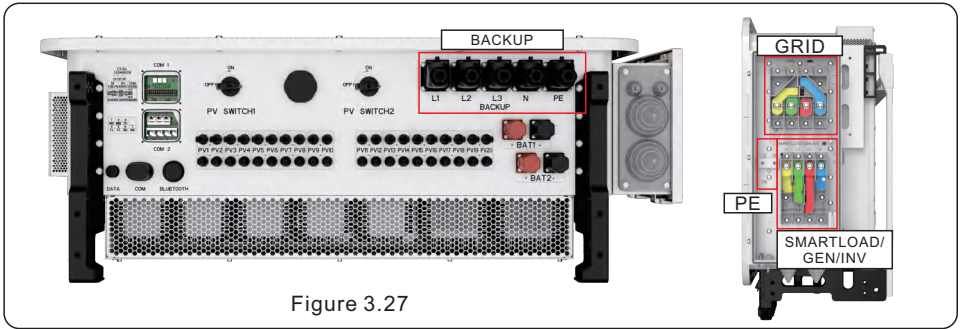

Figure 3.27

Detailed wiring steps are as follows:

1. Disconnect the AC circuit breaker to ensure it won't accidentally turn on.
2. Strip a certain length from the end of the AC cable insulation sheath. The stripping length can be referred to in the following figure. Place the R-type terminals on both ends and make a crimp connection. The crimped part of the terminals must be insulated with heat shrink tubing or insulating tape.

Max inverter backfeed current to PV array: Current 0A , Continuous 0 ms.

Maximum output fault current on grid port:

Max. peak current: 520A, total duration:132ms.

Current (inrush) on grid port: Max. peak current 50A , Max duration 9.2ms.

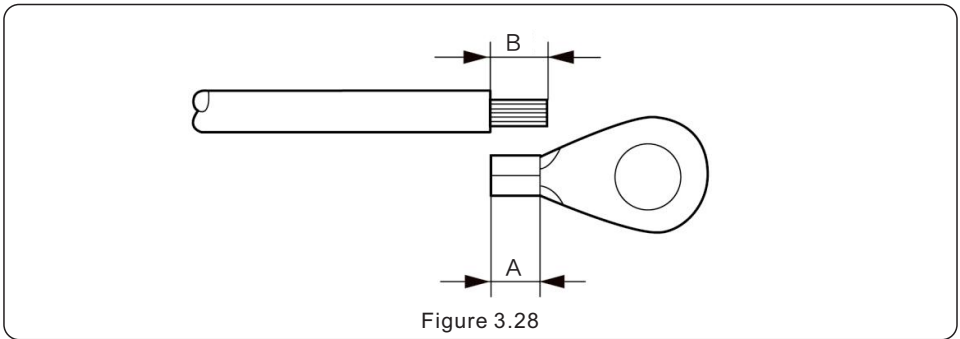

Figure 3.28



NOTE

B (insulation stripping length) is 2mm - 3mm longer than A (OT cable terminal crimping area).



NOTE

Currently, aluminum wire connections are supported, but the backup aluminum wire can only reach a maximum of 95mm^2 . If it exceeds 95mm^2 , load reduction may be required; the wire nose can only use copper-aluminum alloy (the copper-aluminum alloy wire nose is configured according to the selected cable).

4. When connecting to the grid port and the SMARTLOAD/GEN/INV ports, remove the three screws on the cover of the inverter junction box, and then remove the junction box cover.



Figure 3.29

5. Select the matching diameter of the outlet sealing ring according to the diameter of the AC cable. Cut the diameter of the sealing ring to the appropriate size, pass the cable through the sealing ring, remove the nut at the corresponding position of the wiring box, and use a socket wrench to connect the cable to the corresponding AC terminal block in sequence. The torque should follow the recommended torque in table.

6. To ensure the waterproof effect, the operator needs to regularly check if the sealing ring is damaged.

7. When the cable is coming out in right wiring box, there should be no openings or gaps between the tower protective sleeve and the cable.

8. After the AC cable are wired, the cables should be fixed, The installers should use the ribbon to secure the wire harnessed in the holes of the surrounding metal shells.



WARNING:

Do not short-circuit the GRID N and Backup N wires within the wiring box. Failure to comply may result in equipment damage, electric shock, or fire hazard.

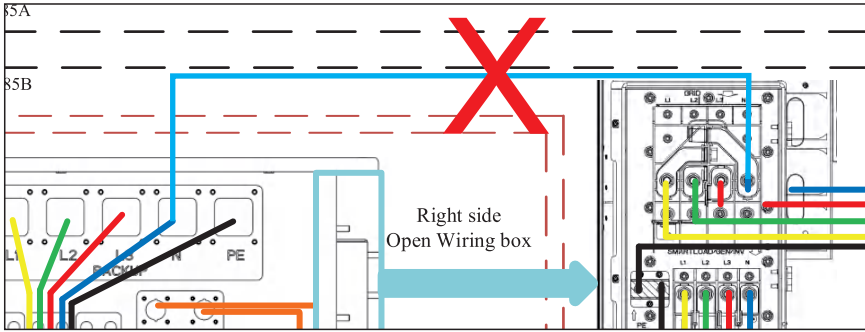

Figure 3.30

3.11 Meter/CT Connection



CAUTION:

Make sure the AC cable is totally isolated from AC power before connecting the or CT.

3.11.1 CT Installation

The CT provided in the product box is compulsory for hybrid system installation. It can be used to detect the grid current direction and provide the system operating condition to hybrid inverter.

CT Model: AKH-0.66-K-80*40-600A

CT Cable: Size – 0.8mm², Length – 5m, its extension not supported.

CT connection: On the inverter side, it is directly inserted through the quick-insert terminal; on the grid side, it is connected through the U-shaped terminal.

Solis marked the CT cable in 6 different colors .lead the CT cables through the COM 1 port of inverter bottom.

CT Wire	8 PIN Communication Terminal Block	Print name
Black	Pin 1 (From Left to Right)	L1CT+
Purple	Pin 2 (From Left to Right)	L1CT-
Orange	Pin 3 (From Left to Right)	L2CT+
Blue	Pin 4 (From Left to Right)	L2CT-
Yellow	Pin 5 (From Left to Right)	L3CT+
Green	Pin 6 (From Left to Right)	L3CT-

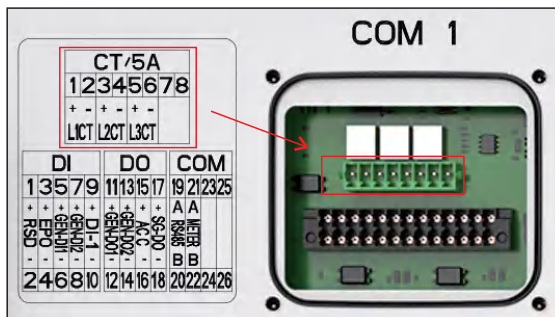

Figure 3.31

3.12 Inverter Communication

3.12.1 Communication Ports

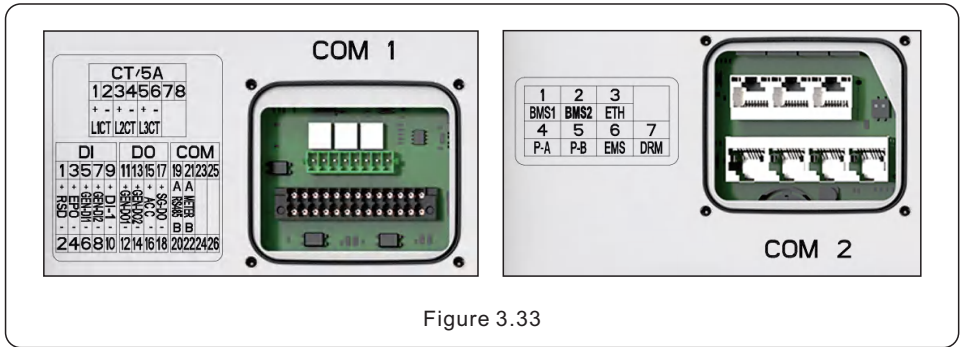

Figure 3.33

Wiring steps for COM1-COM2:

Step 1. Loosen the cable gland and remove the watertight caps inside the cable gland based on the number of the cables and keep the unused holes with watertight cap.

Step 2. Lead the cable into the holes in the cable gland.

(COM1/COM2: 7-hole , Hole Diameter: 6m)

Step 3. Connect the cable to the corresponding terminals inside the wiring box.

Step 4. Reassemble the cable gland and ensure there is no bending or stretching of the cables inside the wiring box.



NOTE:

Please separate the gap with hand and squeeze the cables into the holes from the side openings.

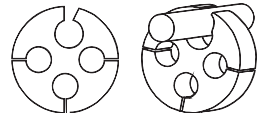

3.12.2 Communication Terminals

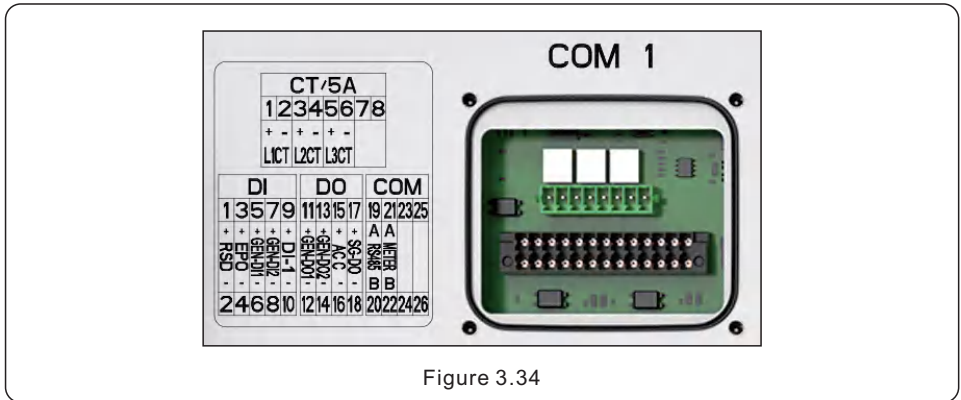

Figure 3.34

Terminal	Type	Description
CT	Push-In Terminal	For CT connection.
RSD		The positive and negative electrodes are short-circuited at the factory, the inverter will stop when disconnected. If customer has the requirement for RSD Function They need to use an external switch or external controller to control it.
EPO		Same logic as RSD function, Customized functions can be accepted from customers, allowing them to choose whether to shut down the system or merely stop PV output on this function.
GEN-DI1		Used for external ATS dry contact signal transmission.
GEN-DI2		Used for external power adaptor(DC12V/5V) dry contact signal transmission.
DI-1		Reserved for customized function.
GEN-DO1		Used for Generator start/stop signal. Generator connection: Grid side or GEN port.
GEN-DO2		Used for Generator start/stop signal. Generator connection: Only GEN port.
AC C		Used for hybrid inverter control the external breaker to cutoff the PV inverter AC connection with hybrid inverter smart port.
SG-DO		Used for heat pump.
RS485		Used for Solis Grid-tied inverter communication.
METER		Used to meter connection.

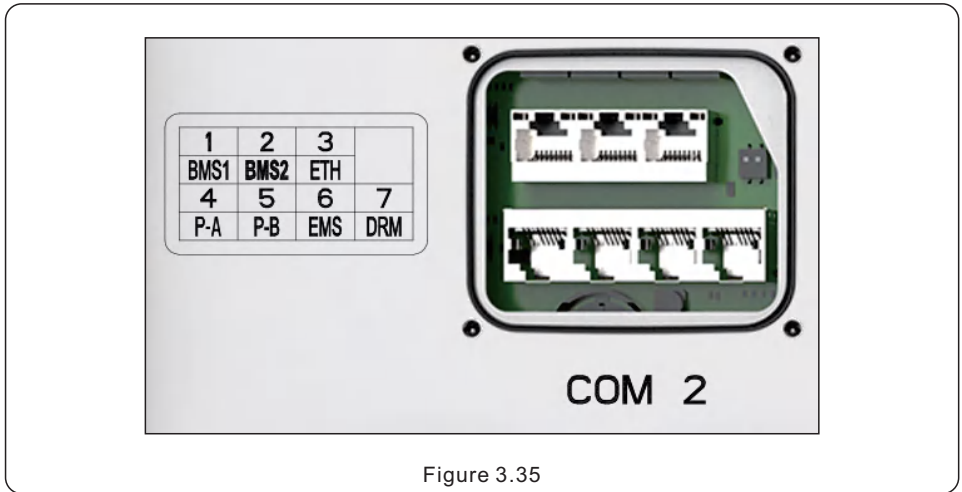

Figure 3.35

Terminal	Type	Description
BMS1	RJ45 Connector	For battery communication (CAN protocol).
BMS2		For battery communication (CAN protocol).
ETH		Ethernet port, support TCP/IP, used for other external communication, the standard Ethernet Port definition: 1-TX+,2-TX-,3-RX+,6-RX-.
P-A		For parallel mode connection between inverters.
P-B		For parallel mode connection between inverters.
EMS		For external 3rd party EMS control.
DRM		For DRM function requirement in some regions.
DIP Switch	Switch	If a inverter is set as the first or last inverter in the parallel connection, you need to put all the DIP switch on this inverter to ON state , and the middle machine should be on OFF state.

3.12.3 BMS Terminal Connection

3.12.3.1 With Lithium Battery

CAN communication is supported between inverter and compatible battery models. Please lead the CAN cable through the COM1 or COM2 port of the inverter and connect to the BMS terminal with RJ45 connector.

Inverters of this series type support that customers using the batteries with different capacity and with different specification, but Solis recommend that using the batteries with same specification is better for the whole inverter system work excellently.



Figure 3.36



NOTE:

Before connecting CAN cable with the battery, please check whether the communication pin sequence of the inverter and the battery match; If it does not match, you need to cut off the RJ45 connector at one end of the CAN cable and adjust the pin sequence according to the pin definitions of both inverter and battery.

Pin definition of the inverter BMS Port is following EIA/TIA 568B.

CAN-H on Pin 4: Blue

CAN-L on Pin 5: Blue/White

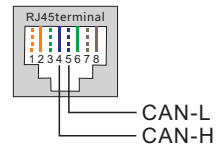

NOTE:

Before connecting RS485 cable with the battery, please check whether the communication pin sequence of the inverter and the battery match; If it does not match, you need to cut off the RJ45 connector at one end of the RS485 cable and adjust the pin sequence according to the pin definitions of both inverter and battery.

Pin definition of the inverter BMS Port is following EIA/TIA 568B.

RS485A on Pin 6: Green

RS485B on Pin 3: Green/White

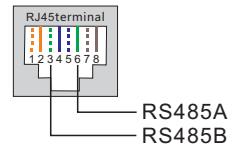

3.12.4 Meter Terminal Connection

The smart meter using the MODBUS as communication protocol, when you want to use the smart meter measurement, you should lead the RS485 meter cable through the com1 port of inverter bottom.

Lead the meter RS485 A cable to 21 pin, RS485 B cable to 22 pin in the internal quick-plug terminal of inverter.

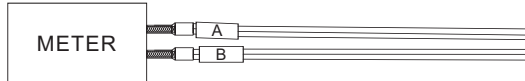

Figure 3.37

3.12.5 DRM Port Connection (Optional)

3.12.5.1 For Remote Shutdown Function

Solis inverters support remote shutdown function to remotely control the inverter to power on and off through logic signals.

The DRM port is provided with an RJ45 terminal and its Pin5 and Pin6 can be used for remote shutdown function.

Signal	Function
Short Pin5 and Pin6	Inverter Generates
Open Pin5 and Pin6	Inverter Shutdown in 5s

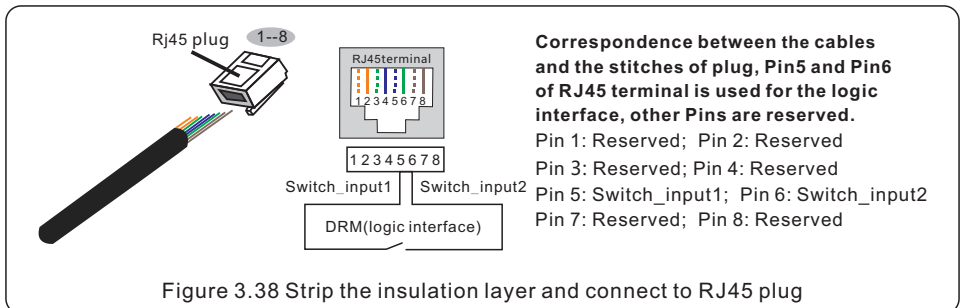

Figure 3.38 Strip the insulation layer and connect to RJ45 plug

3.12.5.2 For DRED Control Function (For AU and NZ Only)

DRED means demand response enable device. The AS/NZS 4777.2:2020 required inverter need to support demand response mode(DRM).

This function is for inverter that comply with AS/NZS 4777.2:2020 standard.

A RJ45 terminal is used for DRM connection.

Pin	Assignment for inverters capable of both charging and discharging	Pin	Assignment for inverters capable of both charging and discharging
1	DRM 1/5	5	RefGen
2	DRM 2/6	6	Com/DRM0
3	DRM 3/7	7	V+
4	DRM 4/8	8	V-



NOTE:

Solis hybrid inverter is designed to provide 12V power for DRED.

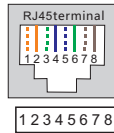

Correspondence between the cables and the stitches of plug

- Pin 1: white and orange ; Pin 2: orange
- Pin 3: white and green; Pin 4: blue
- Pin 5: white and blue; Pin 6: green
- Pin 7: white and brown; Pin 8: brown

Figure 3.39 Strip the insulation layer and connect to RJ45 plug

3.12.6 RS485 Port Connection

This port only supports RS485 communication protocol, and it is dedicated to be used to control a Solis on-grid inverter to realize system control.

For details please refer to Chapter 7.(Pin19: RS485A; Pin20:RS485B)

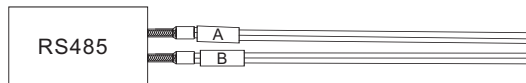

Figure 3.40



NOTE:

The cable length for COM communication connection shall not exceed 500 meters. (EMI-friendly environment).

3.12.7 EMS port connection

This port supports the RS485_MODBUS communication protocol. It can be used as a communication port between the main inverter and third-party EMS. For the communication protocol documentation, please contact the local Solis service team or sales to obtain the latest version.



NOTE:

Pin definition of the RS485 Port is following
EIA/TIA 568B.
RS485A on Pin 5: Blue/White
RS485B on Pin 4: Blue

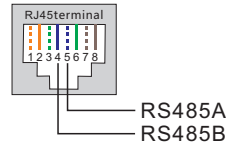

3.13 Inverter Remote Monitoring Connection

The inverter can be remotely monitored via WiFi, LAN or 4G.

The USB type COM port at the bottom of the inverter can connect to different kinds of Solis data loggers to realize the remote monitoring on Soliscloud platform.

To install Solis data loggers, please refer to corresponding user manuals of Solis data loggers.

The Solis data loggers are optional and can be purchased separately.

Dust cover is provided the inverter package in case the port is not used.



WARNING:

The USB type COM port is only allowed to connect Solis data loggers. It is forbidden to be used for other purposes.

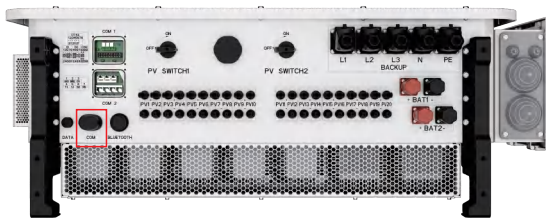

Figure 3.41

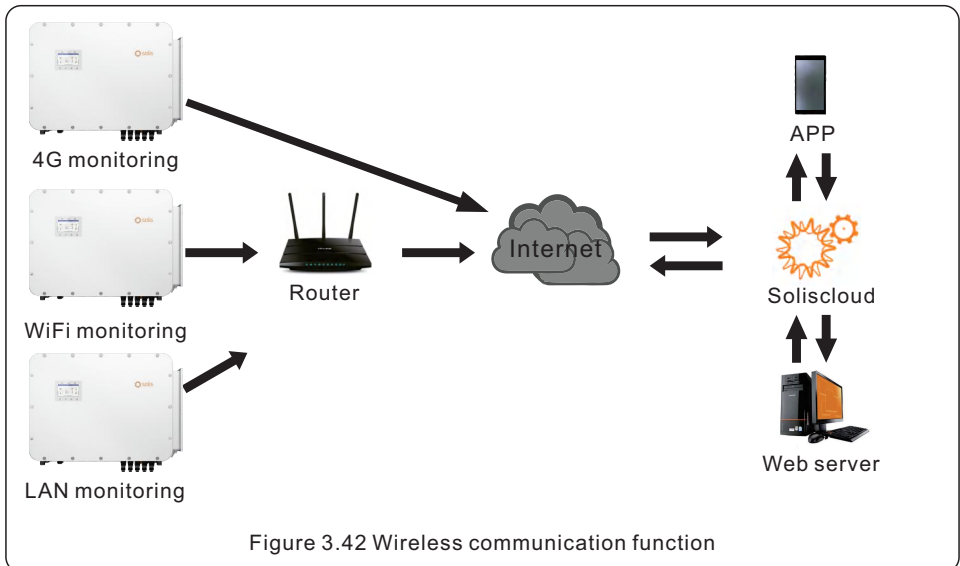

Figure 3.42 Wireless communication function

4.1 HMI Screen

There are 3 indicators and 4 operation button on the Solis S6 Series Inverter.

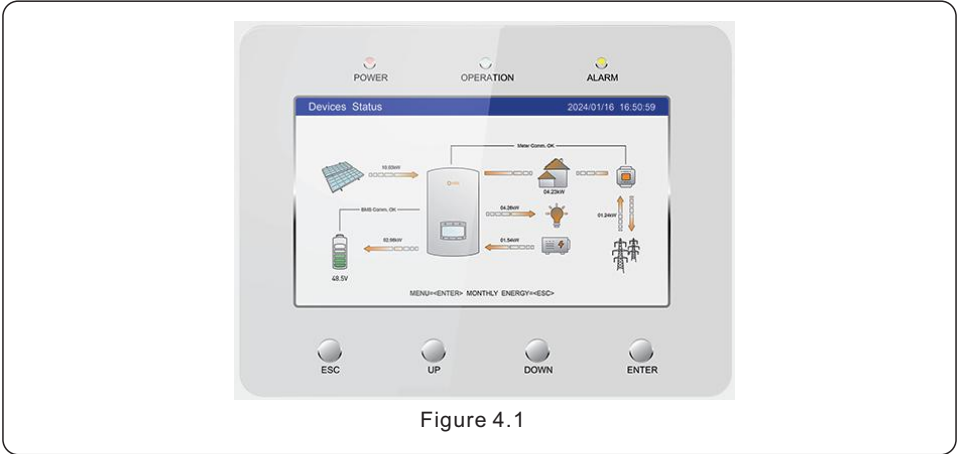

Figure 4.1

Description of indicators:

Indicators	Status	Description
POWER	Red light solid on	Normally powering
	OFF	Not working
OPERATION	Green light solid on	Normally powering
	OFF	No operation
ALARM	Yellow light solid on	Alarm
	OFF	Normal

Description of buttons:

Button	Description
ESC	“Escape”, allows the user to exit, or cancel the operation.
UP	Upwards key, allows the user to increase the value or move forward to the next option.
DOWN	Downwards key, allows the user to decrease the value or move backward to the previous option.
ENTER	Running or executing command .



NOTE:

The screen will be automatically turn off after being idle for a few minutes to save power, click any operation button(“ESC”/“UP”/“DOWN”/ “ENTER”) to restart the screen, then press“Enter”into the main operation interface.

4.2 HMI screen operation system overview

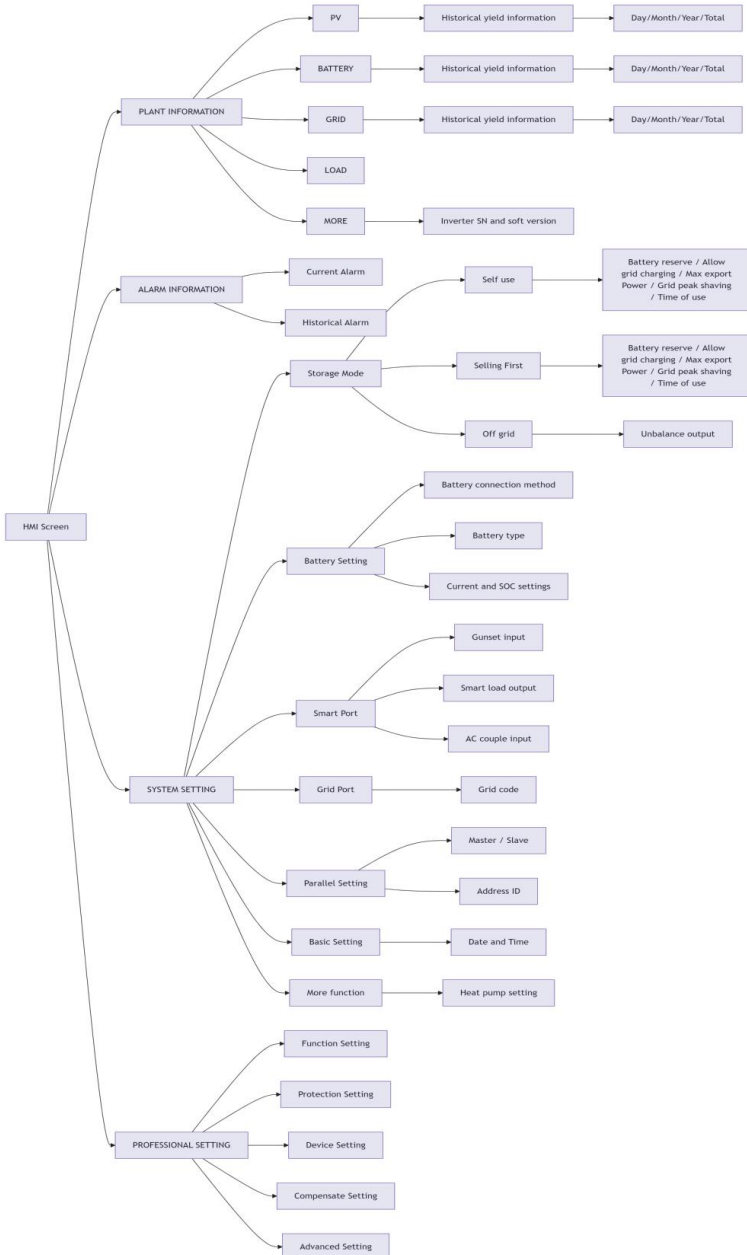

4.3 APP Local debugging interface structure

This inverter supports local debugging on SolisCloud. Communication type: Bluetooth.
The local debugging interface structure is as below:

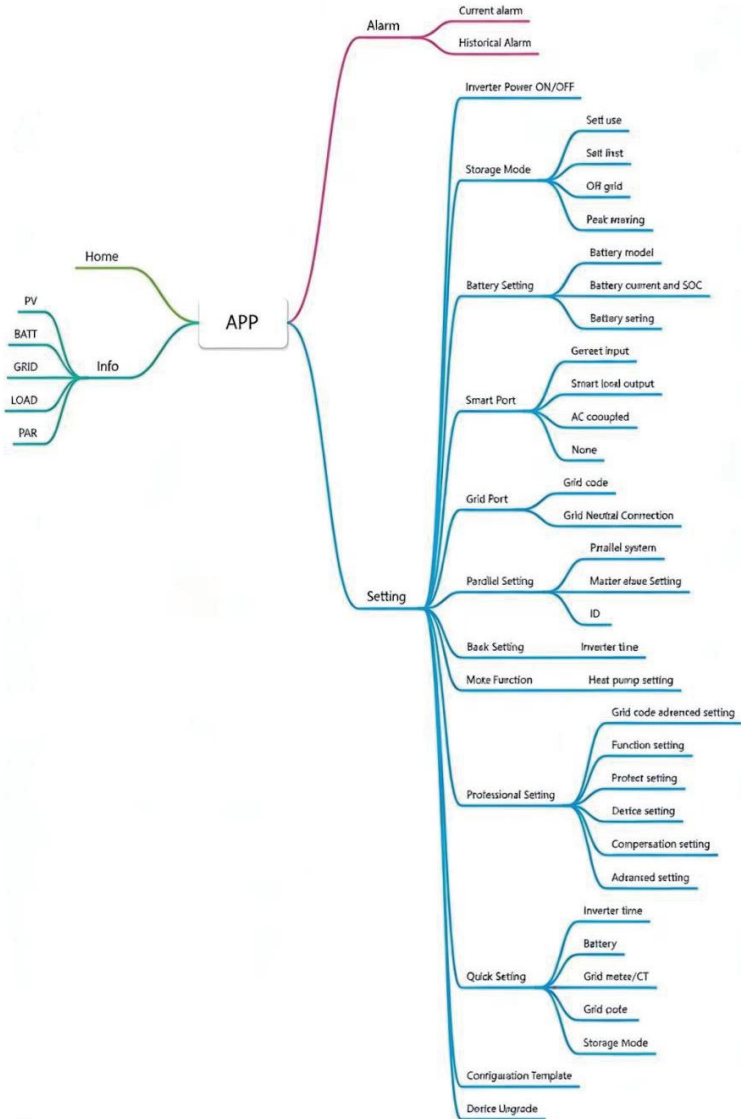

4.4 Inverter built-in Bluetooth description

Bluetooth: BDR、EDR、BLE

frequency band(s) in which the radio equipment operates:2.402-2.480GHZ

Maximum transmitting power: 8dBm

Hereby, Ginlong Technologies Co.,Ltd.declares that the radio equipment type hybrid inverter is in compliance with Directive 2014/53/EU

5.1 Pre-Commissioning

- Make sure that no high voltage conductors are energized.
- Check all conduit and cable connection points ensure they are tight.
- Verify that all system components have adequate space for ventilation.
- Follow each cable to ensure that they are all terminated in the proper places.
- Ensure that all warning signs and labels are affixed on the system equipment.
- Verify that the inverter is secured to the wall and is not loose or wobbly.
- Prepare a multimeter that can do both AC and DC amps.
- Have an Android or Apple mobile phone with Bluetooth capability.
- Install the Soliscloud APP on the mobile phone and register a new account.
- There are three ways to download and install the latest APP.

- 1.You can visit www.soliscloud.com.
- 2.You can search"Soliscloud" in Google Play or APP Store.
- 3.You can scan this QR code to download Soliscloud.



5.2 Power ON

Step 1: With the DC switch off, energize the PV strings and then measure DC voltage of the PV strings to verify that the voltage and polarity are correct. Turn on the battery and check the battery voltage and polarity as well.

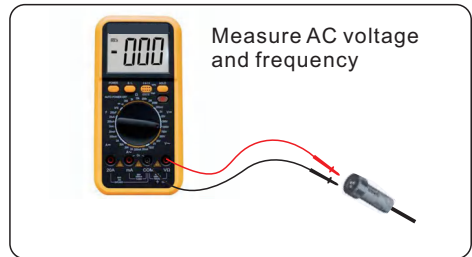
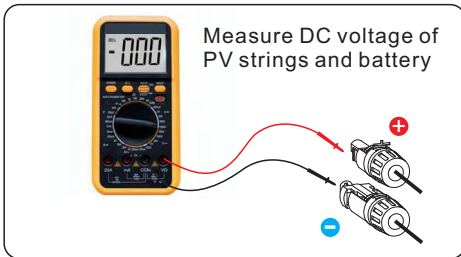

Step 2: Turn on the OCPD for the system and then measure the AC voltages line to line and line to neutral. The backup side of the system will be off until commissioning is complete. Turn the OCPD back off for now.

Step 3: Turn the DC switch on and then the OCPD(AC breaker) for the system. This inverter can be powered on by PV only, battery only and Grid only. When the inverter is powered on,the five indicators will be lighted at once.

5.3 Power OFF

- Step 1: Turn off the AC breaker or AC disconnect switch to disable AC power to the inverter.
- Step 2: Turn off the DC switch of the inverter.
- Step 3: Turn off the battery breaker.
- Step 4: Use a multimeter to verify that the battery and AC voltages are 0V.

5.4 HMI Screen Setting

5.4.1 HMI Quick Setting

If this is the first time the inverter has been commissioned, you will need to first go through the Quick Settings. Once this has been done, these settings can be changed later.

Inverter Time -> Meter Setting -> Grid Code -> Storage mode -> Battery Model

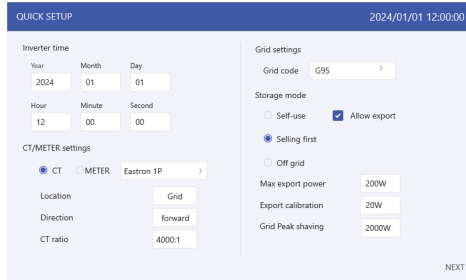

1. Inverter time:

Set inverter time and date, default follow the phone.

2. CT/Meter setting:

Select the CT or Meter, Solis provide Eastron 3 phase meter, it is self-identifiable.

Set installation location: Grid side / Load side / Grid+PV inverter;

CT direction: When CT installed correctly, select "Forward"; when CT installed direction wrong, the sampling current of CT will be reversed when calculating the power, select "Reversal" to correct it.

Set CT ratio: default 120 (Solis provide AKH-0.66-K-80*40-600A), if the user install their own CT, then need to set the CT ratio manually. If the system connected to Meter, then CT ratio need to be set on Meter.

3. Grid code:

Select grid code that meet the local regulations.

4. Storage mode:

ALL modes first priority is to use the available PV power to support loads. The different modes determine what the second priority, or use of the excess PV power, will be.

Self-use / Selling first / Off-grid are exclusive, the user could select only one mode.

5. Battery setting:

Select Battery connection method: 1 Batt 1 DC / 1 Batt 2 DC / 2 Batt 1 DC; the connection method please refer to 3.13 Lithium battery wiring.

Select battery brand (if the connected battery is not on the list, please select "General_LiBat_HV").

Set Max charging/discharging current.

If there are two batteries and share the same settings, please tick the box of "Batt2 Settings follow Batt 1".

5.4.2 Detailed HMI Setting

Step 1: Enter Home page

After quick setting, press “ENTER”, the screen displays the home page.

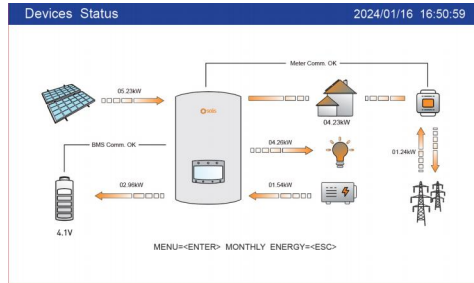

The screen will be automatically turn off after being idle for a few minutes to save power, click any operation button (“ESC”/“UP”/“DOWN”/“ENTER”) to restart the screen, then press “Enter” into the main operation interface.

Step 2: Enter “SYSTEM SETTING” interface

Press “Down” button, then press “ENTER” into the “SYSTEM SETTING” interface.



Step 3: Set “Storage Mode”

Use “UP” or “DOWN” key to select the desired mode, then press “ENTER”.

STORAGE MODE 2024/01/01 12:00:00

Storage mode

Self-use Allow export

Selling first

Off grid

PV power

Batt first Load first

Batt reserved 80%

Allow grid charging

Max export power 200W

Export power calibration 20W

Grid Peak shaving 2000W

1/2

Step 4: Set “Time of use” under each mode (Skip this step if no need)

Time of Use is for manual control of the battery charging/discharging. It is for customizing when the battery is allowed to charge and discharge power and at what rate, established by a current(amperage)setting.

1. Charge period: battery charges with set current value until the charging cut-off voltage (settable), checking the box to control whether enable this charging period.
2. Discharge period: battery discharges with set current value until the discharging cut-off voltage (settable), checking the box to control whether enable this discharging period.

STORAGE MODE 2024/01/01 12:00:00

Charge period

	Start	Stop	Current	SOC
<input checked="" type="checkbox"/>	01 : 00	- 05 : 00	100A	50%
<input type="checkbox"/>	01 : 00	- 05 : 00	100A	50%
<input checked="" type="checkbox"/>	01 : 00	- 05 : 00	100A	50%
<input type="checkbox"/>	01 : 00	- 05 : 00	100A	50%
<input checked="" type="checkbox"/>	01 : 00	- 05 : 00	100A	50%
<input type="checkbox"/>	01 : 00	- 05 : 00	100A	50%

Discharge period

	Start	Stop	Current	SOC
<input checked="" type="checkbox"/>	01 : 00	- 05 : 00	100A	50%
<input type="checkbox"/>	01 : 00	- 05 : 00	100A	50%
<input checked="" type="checkbox"/>	01 : 00	- 05 : 00	100A	50%
<input type="checkbox"/>	01 : 00	- 05 : 00	100A	50%
<input checked="" type="checkbox"/>	01 : 00	- 05 : 00	100A	50%
<input type="checkbox"/>	01 : 00	- 05 : 00	100A	50%

2/2



NOTE:

The set current value is the maximum current for charging/discharging the battery. However, the actual charging and discharging current may not reach this value due to the influence of other factors, such as the maximum charging/discharging power limitation of the inverter, the battery BMS limitation, etc.

Step 5: Set “Battery Setting”

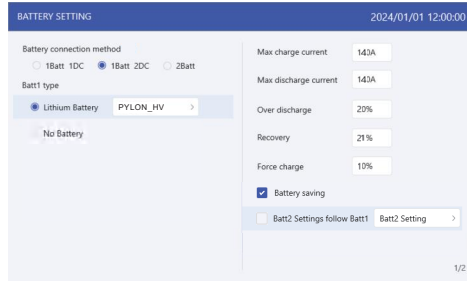

Settings	Description
Max charge current	Max charge current, settable.
Max discharge current	Max discharge current, settable.
Over discharge	Range: 5~40%, default 20%, when battery SOC < over discharge, it will stop discharging.
Recovery	Range: set Over discharge value + 1% ~ set Over discharge value + 20%; The battery can discharge when the SOC/Voltage reaches the set value. Avoid repeated changes in the charging and discharging status of the battery.
Force charge	The battery will be charged to the over discharge SOC/Voltage when it reaches this setting.
Max charge SOC	The maximum SOC/Voltage that the battery can be charged to. Default 100%.

Description of battery mode settings



NOTICE:

Force charge SOC < Over discharge SOC < Recovery SOC, otherwise the setting might be error.

Step 6: Set “Grid Port”

(Skip this step if grid code is already set in quick setting)

Select grid code that meet the local regulations.

Three level of Over-voltage / under-voltage / Over-frequency / under-frequency are default based on grid code, there is no need to set the parameters in manual.

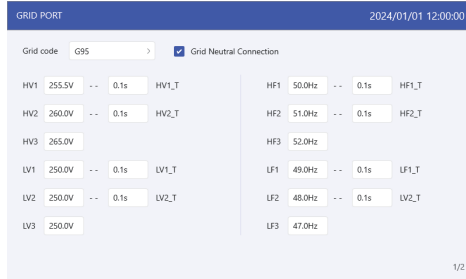

Step 7: Set “Smart Port”

(Skip this step if the system is not connected to generators)

When it is connected to Generator, select “Gunset input”;

When it is connected to smart load like heat pump, select “Smart load output”

When it is connected to Grid-tied inverter, select “AC coupled”

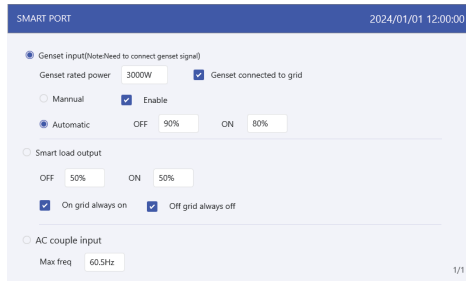

Genset

The user need to input the “Genset rated power” by manual.

OFF: Generator stops charging SOC, settable, range:35%~100%;

ON: Generator start charging SOC; settable, range:1%~95%;

AC coupled:

Max Freq: Grid-tied inverter stops charging frequency, settable,

If grid Level 1 over-frequency threshold <55Hz,

Range: Level 1 over-frequency threshold~ Level 1 over-frequency threshold+ 0.1Hz~54Hz;

If grid Level 1 over-frequency threshold <65Hz,

Range: Level 1 over-frequency threshold~ Level 1 over-frequency threshold+ 0.1Hz~65Hz;

Step 8: Set parallel system

Set Master and Slave machine,

Set Master ID as: 1

Slave machine ID as: 2

.Slave machine ID as: 3

..... and so on.



5.5 APP Setting

5.5.1 Log in the APP via Bluetooth

Step 1: Connect with Bluetooth.

Turn on Bluetooth switch on your mobile phone and then open the Soliscloud APP.

Click "More Tools"->"Local Operation"->"Connect with Bluetooth"

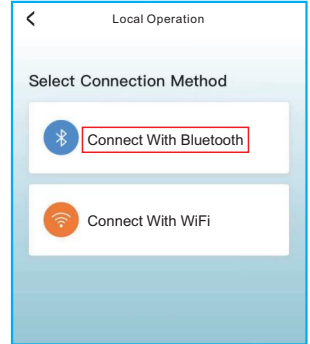
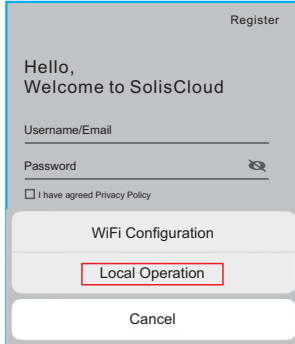
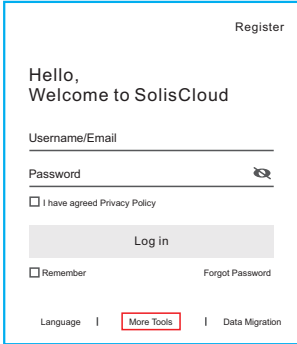

Step 2: Select the Bluetooth signal from the inverter. (Bluetooth Name: Inverter SN)

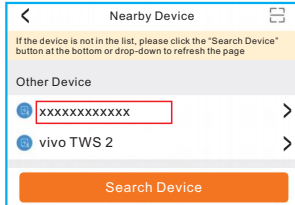

Step 3: Login account.

If you are the installer, please select the account type as Installer. If you are the plant owner, please select the account type as owner. Then set your own initial password for control verification. (The first log-in must be finished by installer in order to do the initial set up)

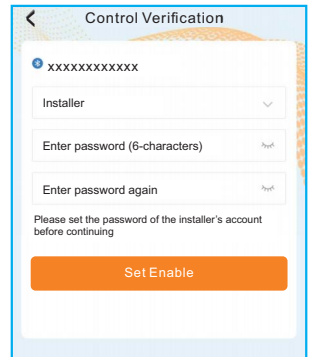
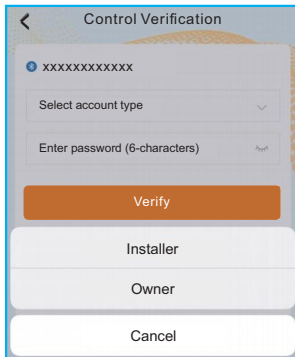
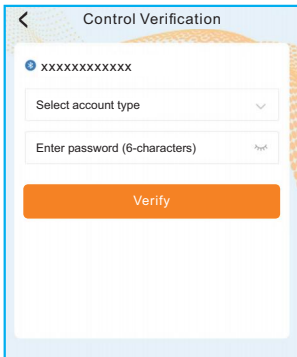

5.5.2 APP Quick Setting

If this is the first time the inverter has been commissioned, you will need to first go through the Quick Settings. Once this has been done, these settings can be changed later.

Inverter Time -> Meter Setting -> Grid Code -> Storage mode -> Battery Model

(1) Inverter time:

Set inverter time and date, tap the slider next to "Follow Phone Time", then tap "Next step" at the bottom right corner.

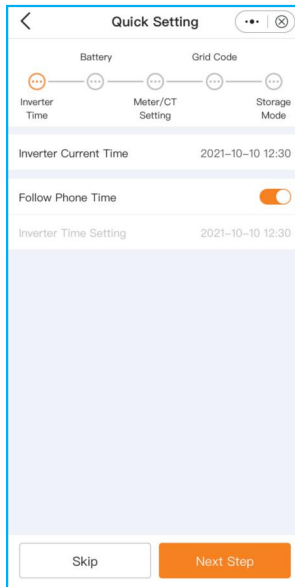

(2)Battery:

- Select number of battery banks : 1-2 ;
- Select battery model: if the connected battery brand is not on the list, please select “Lithium battery HV”
- Select battery connection method.

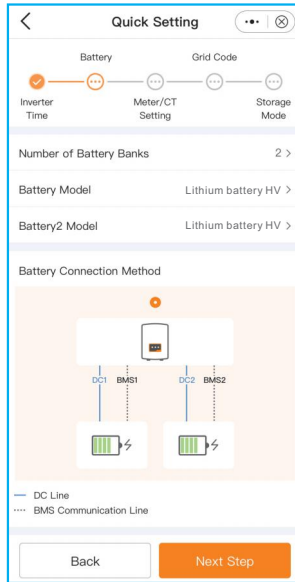
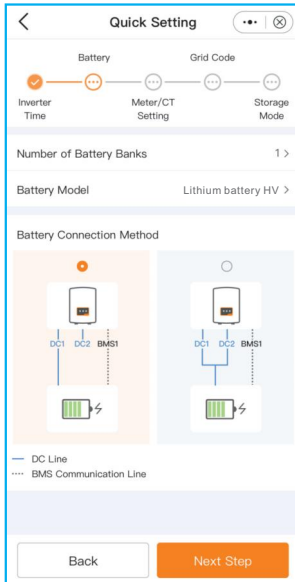

(3)CT/Meter setting:

- Select CT or Meter;
- Set Meter type (Solis provide Eastron 3 phase meter, it is self-identifiable).
- Set Meter installation location: Grid side / Load side / Grid+PV inverter;
- Set CT ratio: default 60 (Solis provide ESCT-T50-300A/5A CT), if the user install their own CT, then need to set the CT ratio manually. If the system connected to Meter, then CT ratio need to be set on Meter.
- CT direction: When CT installed correctly, select “Forward”; when CT installed direction wrong, the sampling current of CT will be reversed when calculating the power, select “Reversal” to correct it.

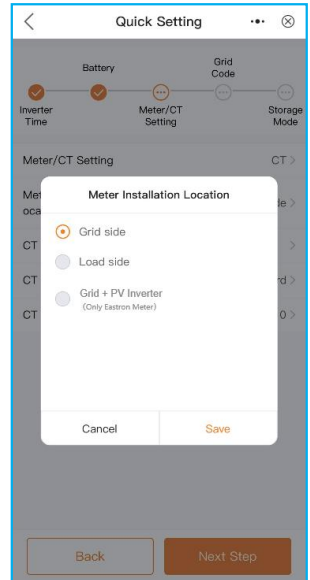
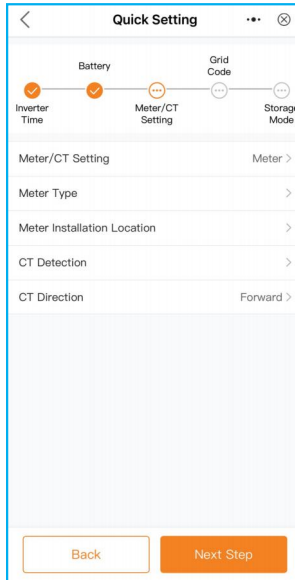

(4)Grid code:

Select grid code that meet the local regulations.

Three level of Over-voltage / under-voltage / Over-frequency / under-frequency are default based on grid code, there is no need to set the parameters in manual.

Parameter	Value	Time	Type
Grid Code	EN50549NL		
HV1	253.0V	1.20s	HV1_T
HV2	253.0V	1.20s	HV2_T
HV3	6553.5V	-0.01s	HV3_T
LV1	184.0V	1.20s	LV1_T
LV2	184.0V	1.20s	LV2_T
LV3	57.5V		
HF1	51.00Hz	1.20s	HF1_T
HF2	51.00Hz	1.20s	HF2_T
LF1	48.00Hz	1.20s	LF1_T
LF2	48.00Hz	1.20s	LF2_T
Startup-VH	253.0V		>
Startup-VL	195.5V		>
Recover-VH	253.0V		>
Recover-VL	195.5V		>

Country/Region
General
User-define
Other
A
Aruba
Australia
Austria
B
Barbados
Belgium
Brazil
C
Chile
China
Cyprus
Czech
D

(5)Storage mode:

ALL modes first priority is to use the available PV power to support loads. The different modes determine what the second priority, or use of the excess PV power, will be.

Self-use / Selling first / Off-grid are exclusive, the user could select only one mode.

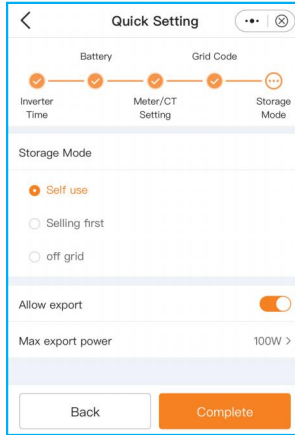

Once quick setting finished, tap "Complete", the APP enter the homepage.

5.5.3 Home

This screen display energy production and consumption, as well as its flow. It shows the following data:

- Today yield of PV
- Today Imported/Exported of Grid
- Today Charged/Discharged of Battery
- Today Consumption of Grid-side load
- Today Consumption of Back-up load
- Today GEN yield.

At the bottom of page are four sub menus: Home, Info, Alarm and Settings.



5.5.4 Routine Setting

Under this page, the user could find quick setting and other detailed settings as follows:

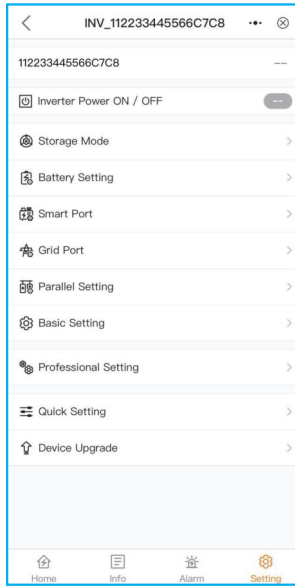

1. Storage mode

a. Select storage mode:

- Self-use / Selling first / Off-grid, these three modes are exclusive, the user could select only one mode. The modes definition could refer to 5.5.2“Quick setting”
- The Mode description please refer to Chapter 7.

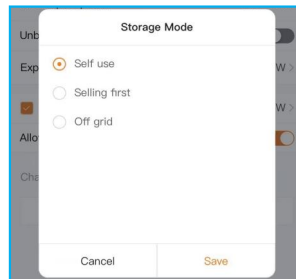
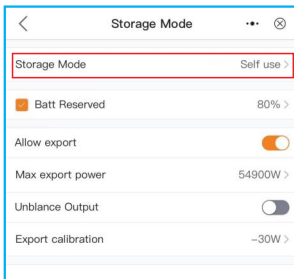

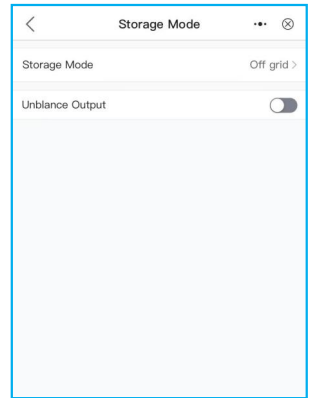
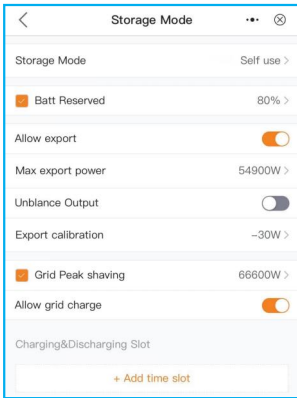

Please notice:

“Allow export” can only be set in “Self use” mode;

“Add time slot” can only be set in grid-connected mode (Self use” mode and “ Selling first” mode).

b. Set mode operations:



NOTE:

Solis's export power control function is based on the sampling results from the smart meter or smart CT. Due to the sampling interval limitation, when the system's load consumption has sudden changes, small amount of export overshooting is expected. For strict zero injection applications, it is suggested to install external backflow trip device as additional protection for injection.

c. Add time slot:

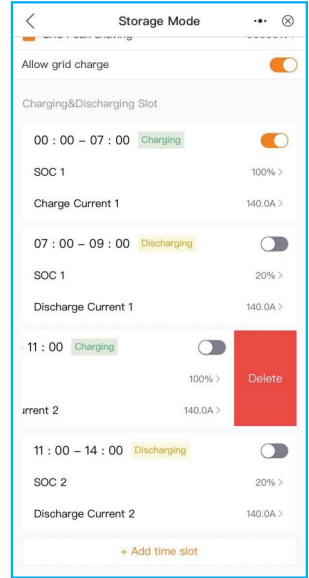
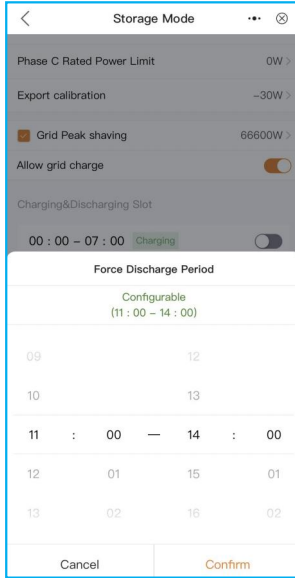
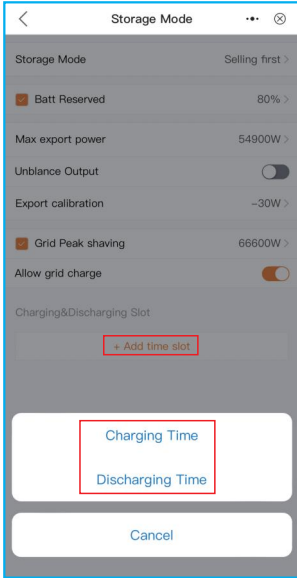

Charge SOC: battery charging stops when reach the set SOC;
Discharge SOC: battery discharging stops when reach the set SOC.



NOTICE:

- Slide the switch to on, the battery charge/discharge with set charge/ discharge current by following the set period
- Slide to the left of screen, the user could delete the current period setting.

2. Battery setting

- Set “ Number of Battery Banks” and “Battery Model”
- Set “Battery Connection Method” : 1 Batt 1 DC / 1 Batt 2 DC / 2 Batt 1 DC;
- Set battery parameters

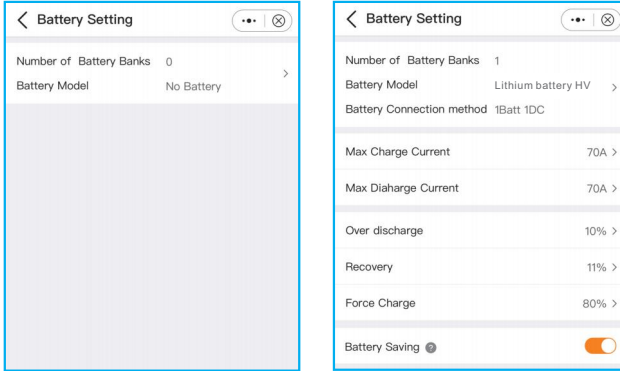

Settings	Description
Max charge current	Max charge current, settable.
Max discharge current	Max discharge current, settable.
Over discharge	Range : 5~40%, default 20%, when battery SOC < over discharge, it will stop discharging.
Recovery	Range : set Over discharge value +1% ~ set Over discharge value +20%; Battery won't stop charging until it reaches Recovery SOC value, reserve the return difference value to avoid the battery repeatedly cross jump between charging and discharging.
Force charge	Range : 4%~ set Over discharge value, when battery SOC < force charge SOC, the grid will charge the battery.

Battery setting



NOTICE:

Force charge SOC < Over discharge SOC < Recovery SOC, otherwise the setting might be error.

d. If two battery banks share the same setting, then turn the “Apply Batt1 parameter values” on. It will match the settings of battery bank 1 automatically.

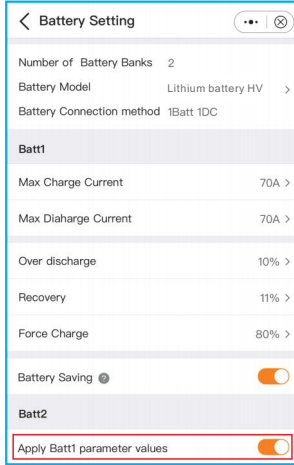

3. Smart port

Select smart port type

- When it is connected to Generator, select “Gunset input”;
- When it is connected to smart load like heat pump, select “Smart load output”
- When it is connected to Grid-tied inverter, select “AC coupled”

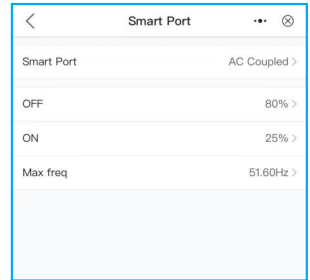
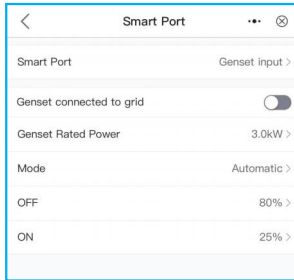
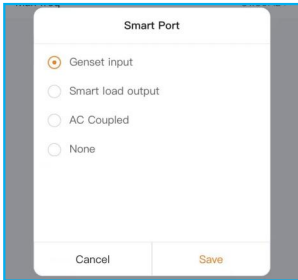

Genset Rated Power: manual input.

OFF: Generator stops charging SOC, settable, range:35~100%;

ON: Generator start charging SOC; settable, range:1~95%;

AC coupled:

OFF: Grid-tied inverter stops charging SOC, settable, range:35~100%;

ON: Grid-tied inverter start charging SOC; settable, range:1~95%;

4. Grid port

Please refer to "5.5.2 APP Quick setting"

5. Parallel setting

When there are ≥ 2 inverters in parallel, turn the slider on

Set Master and Slave machine,

Set Master ID as: 1

Slave machine ID as: 2

.Slave machine ID as: 3

..... and so on.

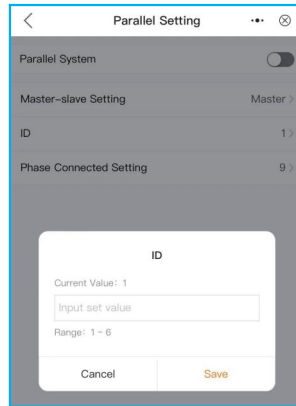
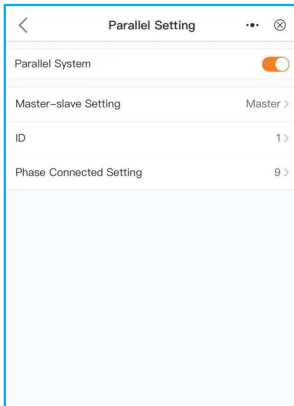

6. Basic setting

Set inverter time and date, tap the slider next to "Follow Phone Time", then tap "Save".

7. CT/Meter setting

There are two ways for CT/Meter setting, detailed setting please refer to “5.5.2 APP Quick setting”.

Method 1: Quick setting

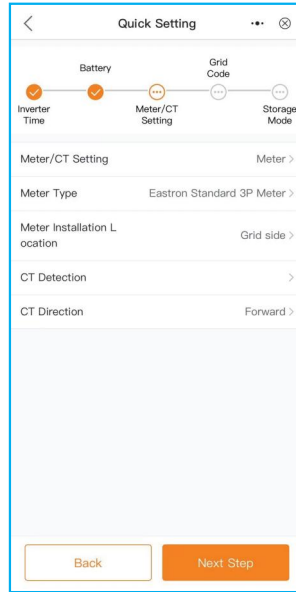
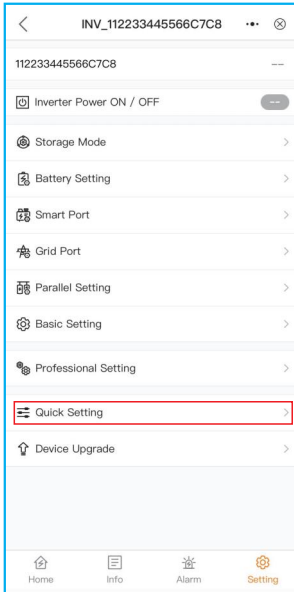

Method 2: Setting --- Professional Setting -- Device Setting --Meter/CT Setting

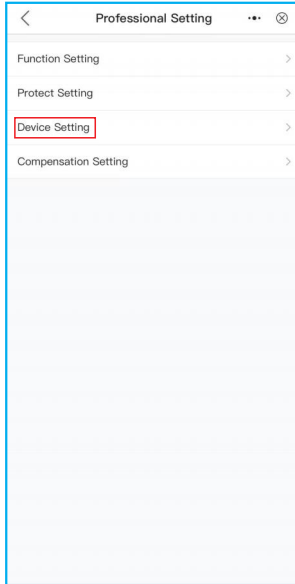
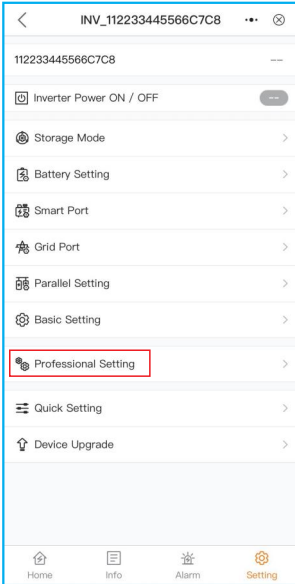

5.5.5 Alarm

The alarm page can display the current alarm and the historical alarms.

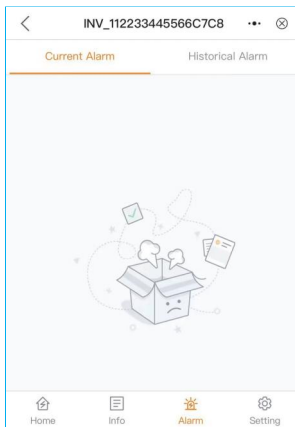

5.5.6 Information

The use could Query information of PV / Battery / GRID / LOAD / INVERTER.

PV : it display each PV module Power/Voltage/Current, as well as historical yield information calculated by monthly / yearly / total, displayed with graphics;

BATT: it display battery Power/Voltage/Current/SOC/SOH/Max.charging current / Max.discharging current, as well as historical battery charging and discharging information calculated by monthly / yearly / total, displayed with graphics;

GRID: it display Active power / voltage/ current of L1/L2/L3, as well as historical exported/imported information calculated by monthly / yearly / total, displayed with graphics;

LOAD: it displays power/voltage of grid load, power/voltage/current of backup load;

INV: it displays inverter SN/model number, and software version.

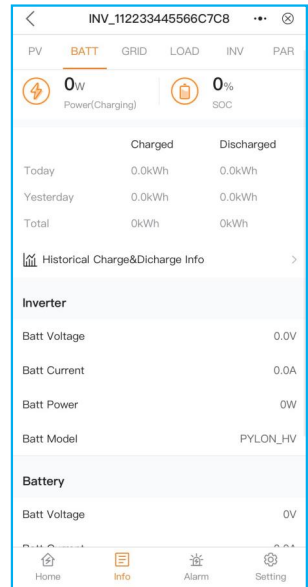
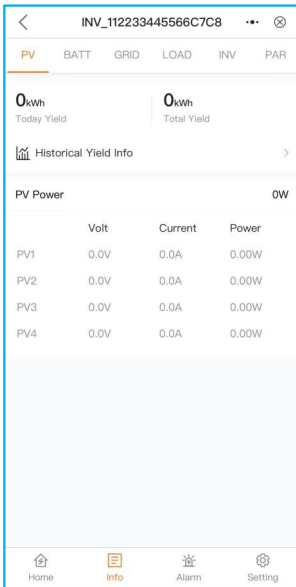

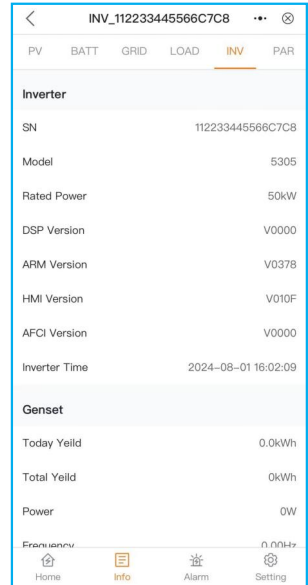
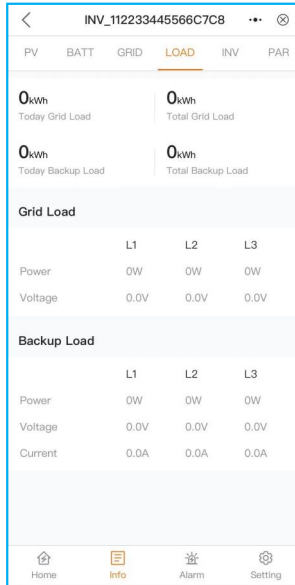
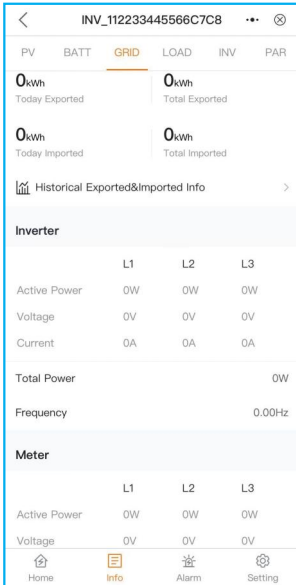

5.5.7 How to enable AFCI function

If you want to enable AFCI function for your inverter, just using the Solis APP and follow the below procedure: Professional Setting —> Protect Setting —> AFCI Protect

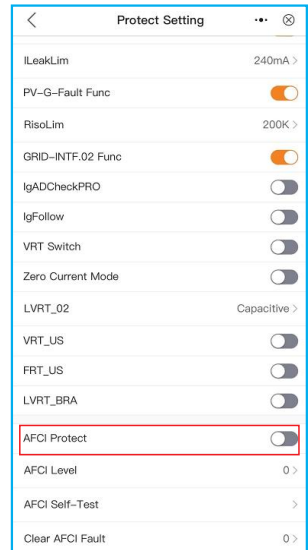
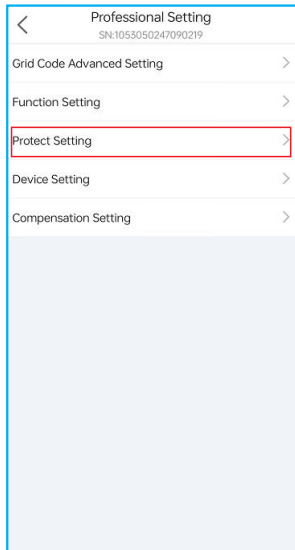
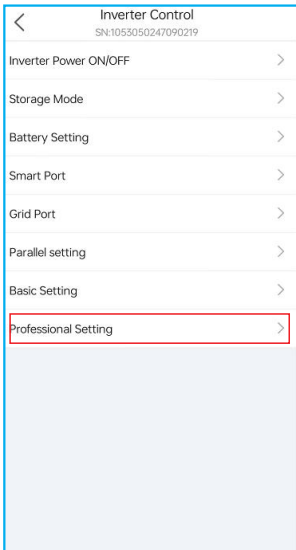

Solis S6 Series inverter does not require any regular maintenance. However, cleaning the heatsink will help the inverter dissipate heat and increase the lifetime of inverter. The dirt on the inverter can be cleaned with a soft brush.



CAUTION:

Do not touch the surface when the inverter is operating. Some parts may be hot and could cause burns. Turn OFF the inverter and let it cool down before you do any maintenance or cleaning of inverter.

The Screen and the LED status indicator lights can be cleaned with cloth if they are too dirty to be read.



NOTE:

Never use any solvents, abrasives, or corrosive materials to clean the inverter.

6.1 Smart O&M

In order to improve our products and provide you with higher quality services, this device has a built-in data logging module for collecting relevant information during operation (such as power generation data, fault data)

Kindly note, this built-in data logging module is only implemented in our specific models that are sent to specific areas.

Commitment:

1. We will only collect, use and process your device information for the purpose of improving our products and services.
2. We will take all reasonable and feasible measures to ensure that no irrelevant information is collected and we will protect your device information.
3. We will not share, transfer or disclose the collected device information with any company, organization or individual.
4. When we stop operating products or services, we will stop collecting your device information in a timely manner.
5. If you do not want to provide such information, you can notify our company to turn off this function, which will not affect your normal use of other functions of the product.

7.1 Storage mode description

Self-Use mode

Solis S6 Series inverter does not require any regular maintenance. However, cleaning the heatsink will help the inverter dissipate heat and increase the lifetime of inverter. The dirt on the inverter can be cleaned with a soft brush.

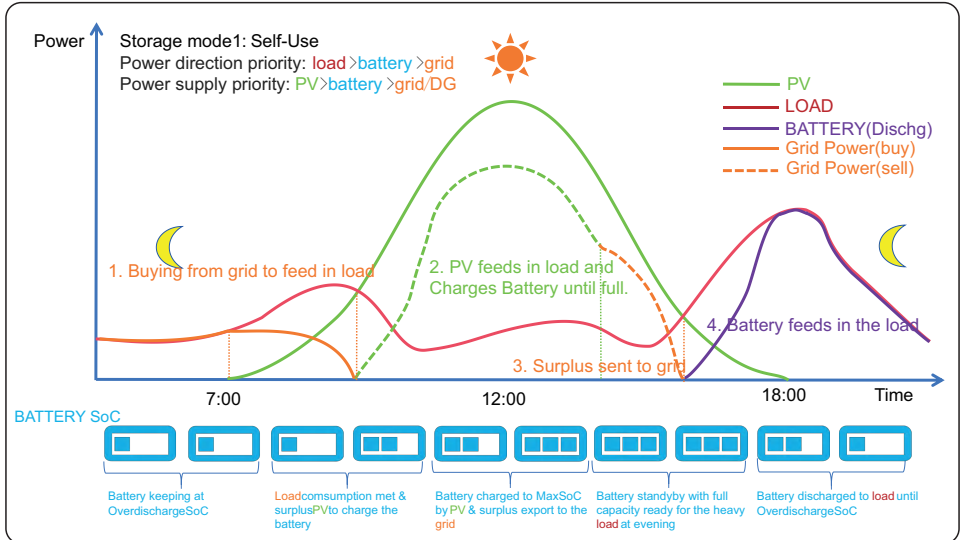

How to set Self-Use mode?

APP: setting--storage mode-self use

1. Self-Use Mode is activated without any specific times set for the battery to be charged/discharged, and the battery reserve is not switched on.

Note: Solis recommends activating the 'Allow Grid Charge' option. Once the battery reaches the Forcecharge SOC, it will use the grid to charge the battery, preventing it from being deep discharged.

2. The Self-Use Mode provides you with the option to set a Battery reserve value. Please toggle the switch to activate the battery reserve mode.

3. The Self-Use Mode provides you with the option to set whether allow power output to the grid and the max value.

4. If there is an error with your meter or CTs, open "Export power calibration" to calibration; In addition, you can set a small negative value (like: -50W) to ensure that no power is sent to the grid to achieve Zero export Power.

5. When your load is unbalanced in the three-phase distribution, turn on unbalanced output.

6. You can set the value of Grid peak shaving, Limit the power that inverters can obtain from the grid to prevent exceeding regulatory requirements or the power line capacity due to excessive power.

7. With the Add time slot, you can customize 6 stages of charging and 6 stages of discharging in one day.

Under each mode , user could set other functions based on their requirements.

Settings	Description
Batt saving	<p>Lithium battery: default 80%, adjustable range</p> <p>This function recommended to be enabled in weak grid area or where grid outages occur frequently.</p> <p>When enabled: battery SOC < set battery reserve SOC, battery will stop discharging and charged from PV/Grid.</p>
Allow export	<p>Allow power output to the grid in Self-use mode.</p> <p>If you do not want to send power to the grid, do not turn it on discharging and charged from PV/Grid.</p>
Max export power	<p>Limit the maximum power sold to the grid.</p>
Export power calibration	<p>To compensate the deviation of CT/Meter in practical application; Value : Settable.</p> <p>Please note : The parallel system should be set at 0.5% of the total capacity of the parallel system; otherwise, the anti-reverse flow performance requirements cannot be met.</p>
Unbalanced output	<p>Allow three-phase output imbalance.</p>
Grid peak shaving	<p>Limit the power that inverters can obtain from the grid to prevent exceeding regulatory requirements or the power line capacity due to excessive power.</p> <p>When the grid supplies power to the load while charging the battery, it will limit the power used to charge the battery, so that the total power does not exceed the set value.</p> <p>If the grid only supplies power to the load and does not charging the battery, it is not limited by the setting value.</p>
Allow grid charging	<p>Allow the battery to be charged by the grid.</p>
Charge/ Discharge Slot	<p>When the time is between Start and Stop, the system will charge/ discharge the battery according to the set Current until the set "SOC/voltage" is reached.</p>

Selling first mode

Load priority: load>grid>battery

Power supply priority: PV>battery>grid>DG

This mode applies to the area that has high feed-in tariff and export control. The PV power will prioritize supplying energy to the load. Then any surplus is directed into the grid.

If there is a feed-in limitation, the excess power will charge the battery.

- Supports TOU setting in this mode.
- Supports Battery Reserve function in this mode.

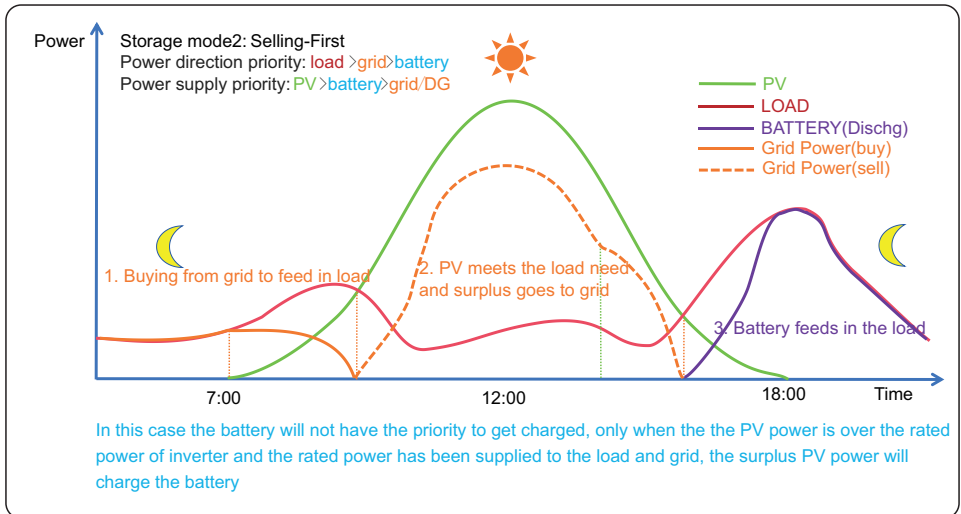

How to set selling first mode?

APP: setting--storage mode--selling first.

Off-Grid mode

Load priority: load>battery

Power supply priority: PV>battery>DG

- This mode applies to the area not covered by the grid or when the system is not connected to the grid.
- When a power outage is detected in a grid-tied system, the system will automatically enter in the off-grid, supplying only the backup load.
- The user can also manually set this mode, supplying only the backup load.

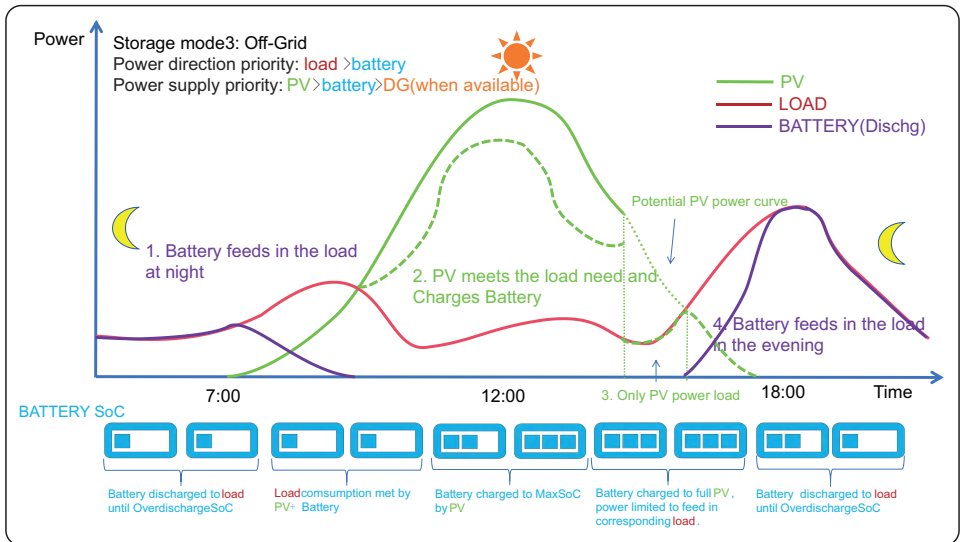

How to set Off-Grid mode?

APP: setting--storage mode--off-grid

When there is need for Off-grid use, make sure that the rated power of the Backup load is within the inverter backup rated output power range of the inverter. Otherwise, the inverter will report an Overload Fault alarm(Fault code: 1057). The inverter will automatically clear the fault when the 1057 overload faults occur. When it keeps alarming there for this fault, turn off some loads to meet the rated backup output power range of the inverter, and then restart the inverter for a response.

For inductive loads such as refrigerators, air conditioner, washing machine, etc., ensure that the start power in total does not exceed the Backup peak power of the inverter.

Type of load	Equipment	Start power
Resistive load	Lamp	Rated power
	Fan	
	Hair dryer	
Inductive load	Refrigerator	3-5 times rated power
	Air conditioner	3-6 times rated power
	Washing machine	3-5 times rated power
	Microwave oven	3-5 times rated power

Peak shaving mode

Step1:

Setting--Grid peak shaving(turn on and set the limit value)

Step2:

Setting--Professional(password: 0010)--Function Setting--peak shaving.

In this mode, Power supply priority:

PV>grid>battery>DG(when BAT SOC≤baseline SOC);

PV>battery>grid>DG(when BAT SOC≥baseline SOC);

on the premise that the power supplied by the grid does not exceed the set value(P_max), the system will be trying to charge the battery to Peak SOC.

If(P_discharge+P_max+PV<P_load), it will exceed the set value(P_max)to support the load.

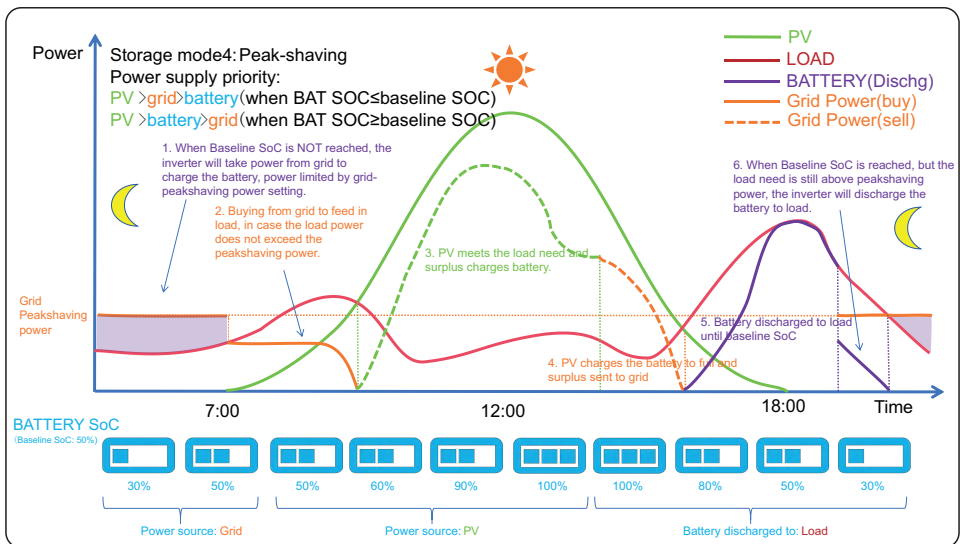

Settings	Description
Max export power	Default: 1.1 times of rated power. Notice: if feed-in is not allowed, set Max export power to 0.
Export calibration	To compensate the deviation of CT/ Meter in practical application . The parallel system should be set at 0.5% of the total capacity of the parallel system; otherwise, the anti-reverse flow performance requirements cannot be met.
Grid peak shaving	Default enable, default 2 times of rated power. Limit the power drawn from the grid to prevent from exceeding regulatory requirements or the power line capacity.

7.2 Time Of Use

Set “Time of use” under each mode (Skip this step if no need)

Time of Use is for manual control of the battery charging/discharging. It is for customizing when the battery is allowed to charge and discharge power and at what rate , established by a current (amperage)setting.

This function has prior logic to other storage modes.

- 1 . Charge period: battery charges with set current value until the charging cut-off voltage (settable), checking the box to control whether enable this charging period.
- 2 . Discharge period: battery discharges with set current value until the discharging cut-off voltage (settable) , checking the box to control whether enable this discharging period.

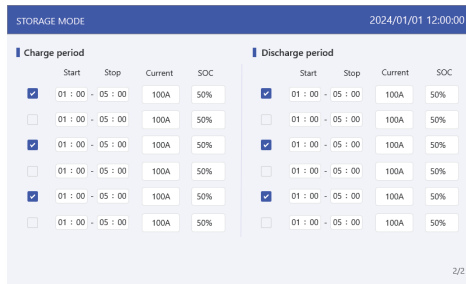

7.3 AC coupling system

Generally, the access of grid-tied inverter is for the retrofit of a existing PV plant.

The S6 hybrid inverter support access of both Solis grid-tied inverter and third-party grid-tied inverter.

And S6 hybrid support two ways of connection of grid-tied inverter (Smart port and grid side)

1. Access of grid-tied inverter(Smart port)

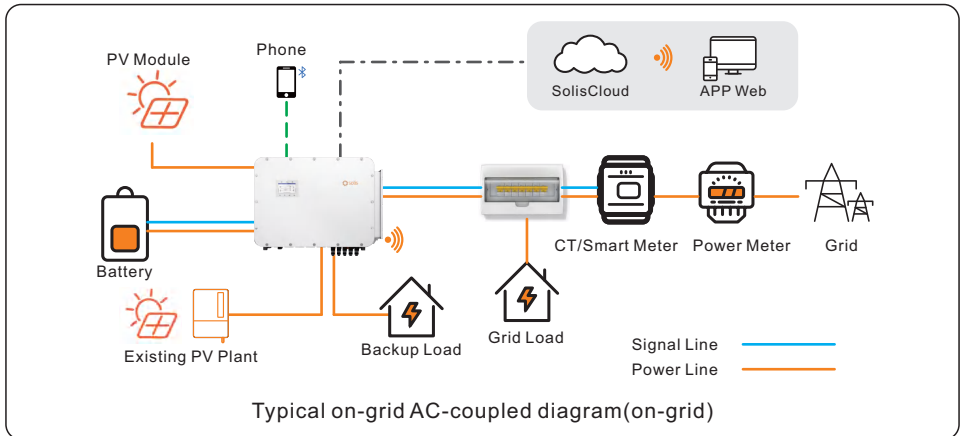

(1)Requirements of grid-tied inverter

- Rated power of grid-tied inverter \leq Hybrid rated power;
- Only support three phase grid-tied inverter. Single phase grid-tied inverter not supported;

(2)Control logic

- On-grid scenario: Hybrid and grid-tied inverter are grid follower, hybrid cannot control the output power of the grid-tied inverter, it controls the smart port relay between hybrid and grid-tied inverter to achieve 0 export(When battery SOC > fixed SOC, hybrid will turn off the smart port relay to stop the output of grid-tied inverter).
- Off-grid scenario: Hybrid acts as grid former and control the output of the grid-tied inverter by adjusting the frequency, the third-party grid-tied inverter must be configured with the correct grid code and equipped with over-frequency load shedding and under-frequency load rising functionalities.

(3)Setting path

【Smart port-----AC coupled----Max export control----based on export power&SOC】

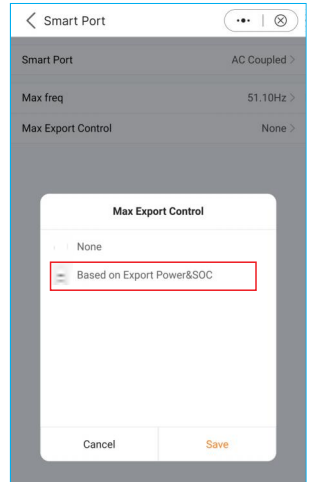
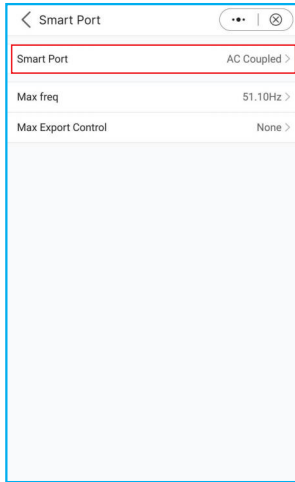
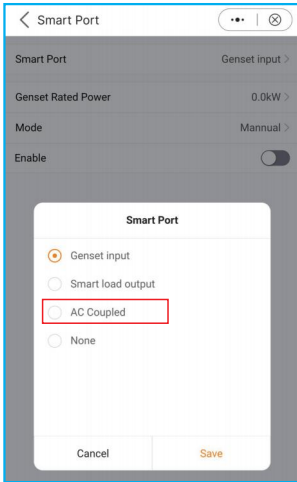

Access of third-party grid-tied inverter(Grid side)

Working with grid-tied inverter and monitor the grid-tied inverter output via meter. The output power of the grid-tied inverter can be displayed on soliscloud use the same meters in parallel.

Meter1 address: 001 (grid side), meter2 address: 002 (PV inverter).

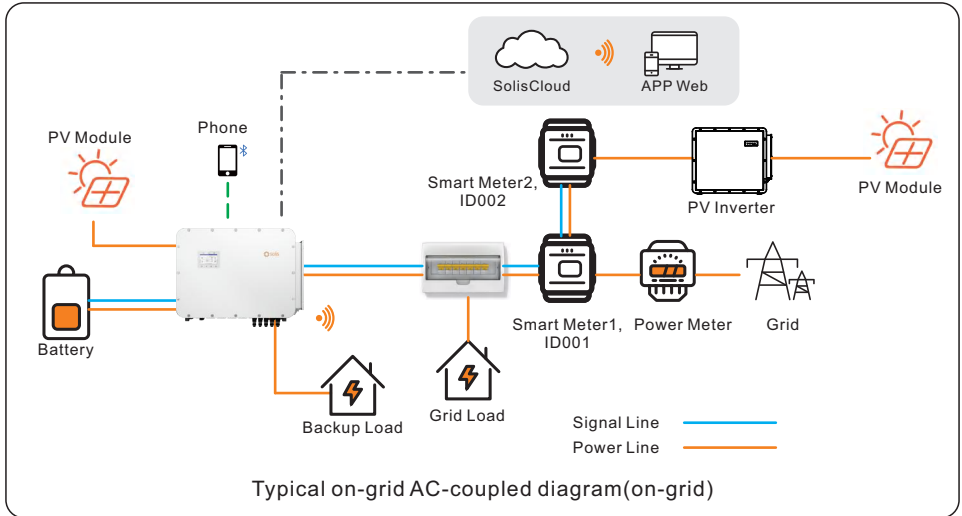

For specific dual-meter wiring, please refer to the diagram below.

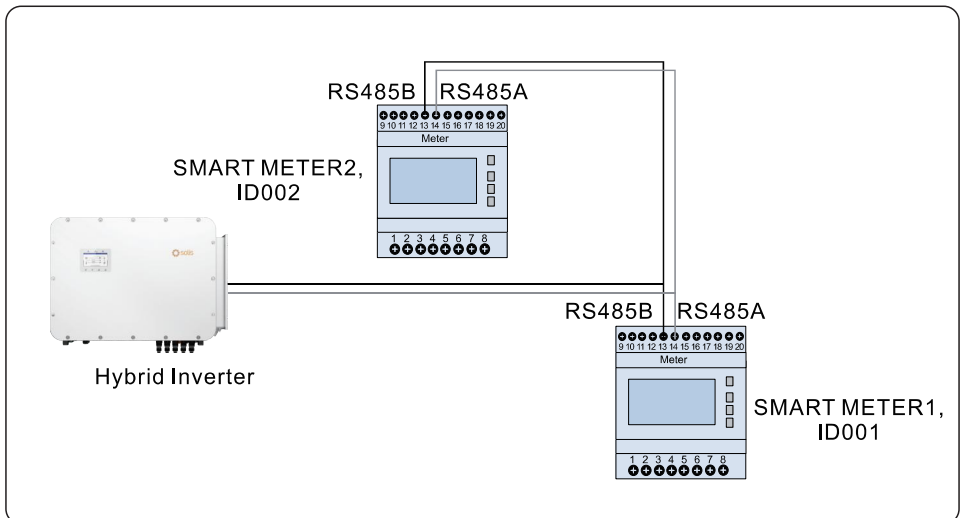

Procedure:

Step 1: Select the Professional Setting

Step 2: Select the Device Setting

Step 3: Select the Meter/CT Setting---- Meter

Select the Meter Type---- Meter

Select the Meter/CT Installation Location----Grid +PV Inverter



NOTE:

If there is need for the hybrid inverter to control the whole AC-Coupled system to reach zero export, Solis Grid-tied inverter must be used for communication.

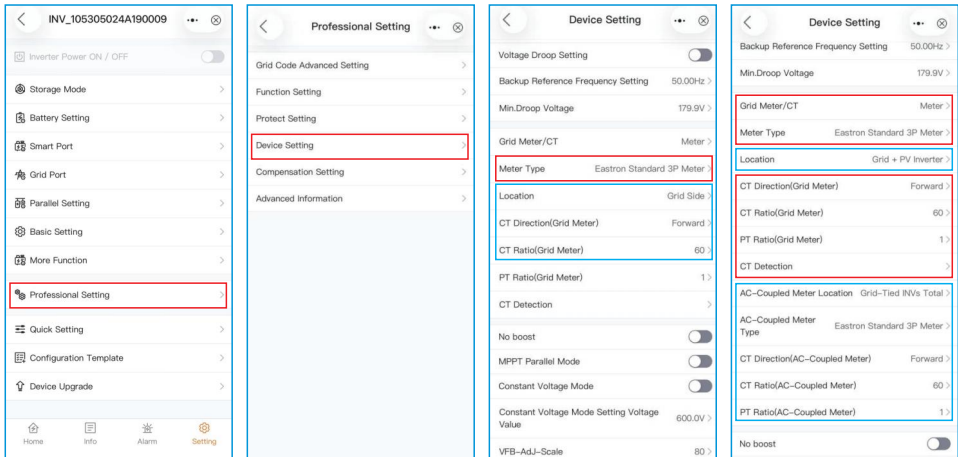

7.4 Generator integrated system

1. The backup PE must be directly connected to the PE copper bar of the power distribution box, rather than the inverter shell.
2. The generator itself needs to be grounded, connected to the electric box, and connected to the inverter generator port.
3. When the generator is working, disconnect the Grid breaker or leakage current protector on the side of the power box immediately.



NOTE:

If you want use the smart port to connect a generator, there is no limit to the generator capacity. However, the maximum active power that the smart port can obtain from the generator is 125 kW. We recommend that the generator power should be in the range: 25 kW~ 125 kW.



NOTE:

If you need connect the generator on inverter smart port or inverter grid port , when you are connecting the power cable, you should keep the cable conned in right correspond phase sequence.
For example: if you do the wrong operation , like connecting the A phase point form Inverter to the B or C phase point from generator, when you want start generator, the inverter will report alarm and the generator cannot start normally!

7. Feature Introduction

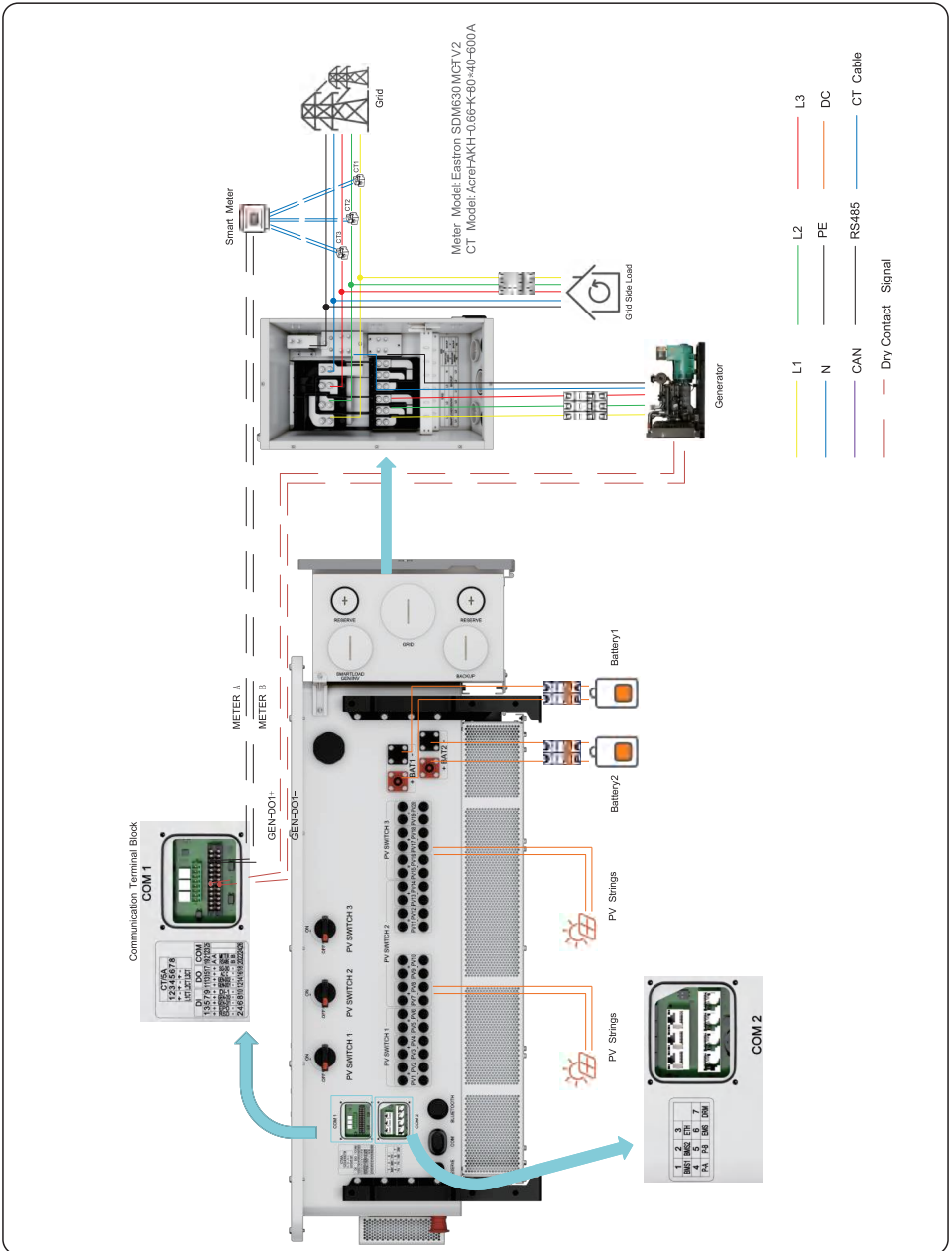

Generator communication connection(GEN-DO1/GEN-DO2/GEN-DI1/GEN-DI2)

The GEN-DO1(Pin11 , Pin12) , GEN-DO2(Pin13 , Pin14) are DO ports. You can use this ports to output dry contact signal to generator to control the generator start or stop automatically.

Both GEN-DO1 & GEN-DO2 are normally open and only close when generator startup logic is triggered.

The GEN-DI1 (Pin5 , Pin6), GEN-DI2 (Pin7 , Pin8) are DI ports , these two ports can be used when you connect the generator on the grid side with an ATS.

The GEN-DI1(Pin5, Pin6) on the inverter is dedicated to connect to the ATS on the dry contact point, when the grid is down, the ATS will close/connect the circuit of the dry contact, then the inverter can identify and enter generator operation mode, when the grid comes back, the dry contact will be open/disconnected and vice versa for the inverter.

The GEN-DI2(Pin7, Pin8) on the inverter is dedicated to connect to a power adapter(220V.ac~to 5/12V.dc) on the grid side. This power adapter will follow the available/unavailable status with the grid by providing 5/12V or 0V to the inverter so that the inverter knows when the grid is down or comes back and acts accordingly.

7.5 Parallel system

1.Before doing the parallel mode, please upgrade all the inverter to the latest version(ARM&DSP).

2.Check if the inverters are the same model. Eg, match a 125kW inverter with 125kW inverter.

Do not install inverters in parallel mode from different model!

3.When there are up to 6pcs of inverters working in parallel mode, the on-grid to off-grid switching time is less than 20ms. When there are up to 7~10pcs of inverters working in parallel mode, please contact Solis technical team.

4.It is recommended that the specification and total capacity of battery on the master and slave inverter be same; If it's different, connect the battery of larger capacity to the master inverter, if the battery with larger capacity is connected to a slave inverter , may fail to fully discharge in heavy load scenarios.

5.Parallel connection of Battery port is not supported between each inverter, each inverter should have its own battery connected independently.

6.When the current on each phase of the grid side is over 300A, for which indicates sum of the load and the inverter system output capacity, customers need to equip their own CT, which can meet the secondary side current of 5A.

7.Max. total parallel distance: <60m

We recommend that the backup load of the parallel system be configured at 90% of the system's rated power.

ON/OFF Grid

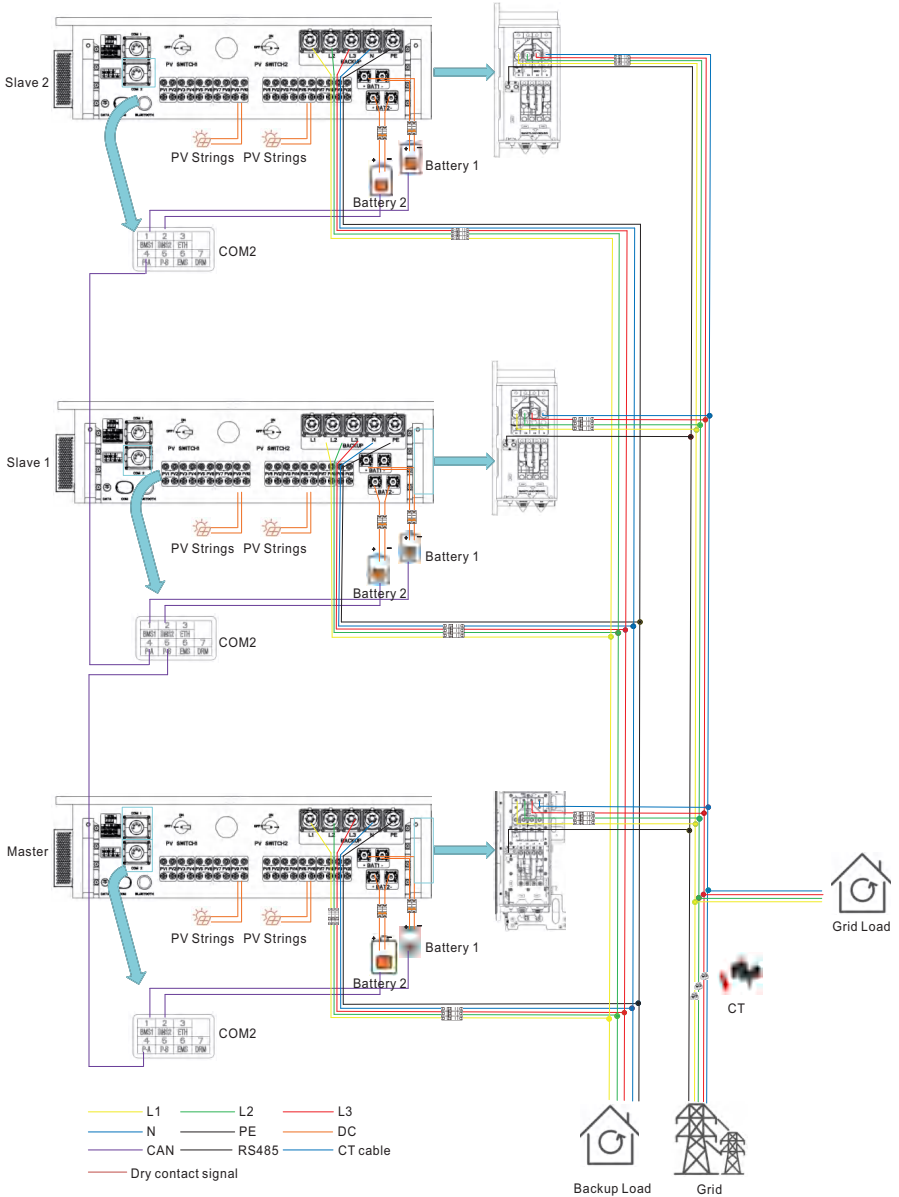

OFF Grid

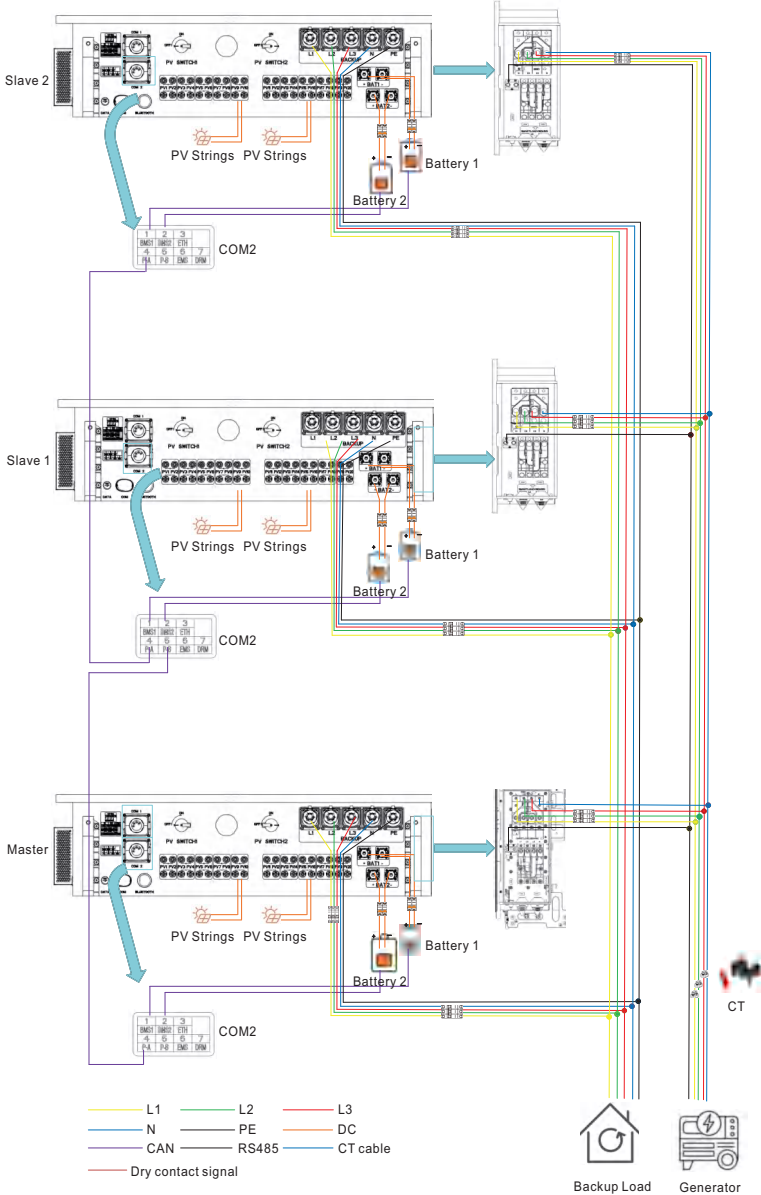

Up to 6 units of the inverter can be connected in parallel, if you have demand for 7-10 pcs in parallel mode, you should ask local solis technology support.

Please connect the paralleled inverters by using P-A and P-B terminals.

Standard CAT5 with shielding layers internet cable can be used.

1. ALL inverter MUST be connected to their own HV battery.
2. NOT support two or more inverters connect to the same one battery.

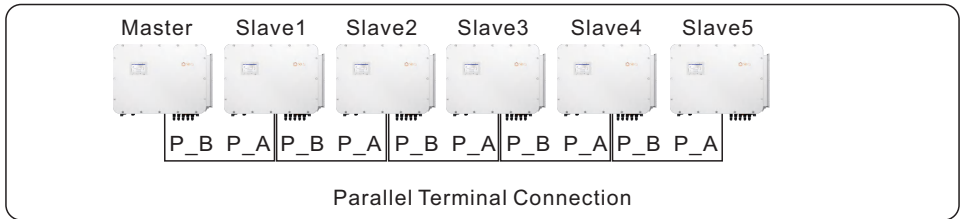
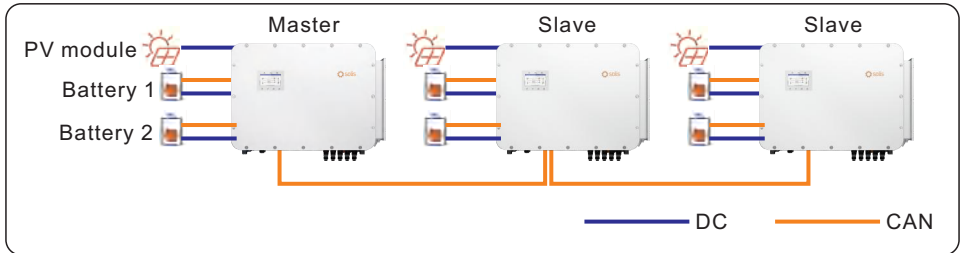

NOTE:

The master is set with an ID of 1, Slave1 should have an ID of 2, Slave2 should have an ID of 3, and so on.

In a parallel system, if the battery number configuration is not one-to-one sufficient, only the slave machine can be left unconnected, while the master machine must be connected to the battery.

And the battery which one has the highest capacity we recommend you connect it to master machine is better for system stability.



NOTE:

If the parallel machine is connected to the first and last consoles of the parallel connection, you need to put the DIP switch on the ARM board to "ON" position, and all the middle machines' DIP switch should be put to "OFF" position.

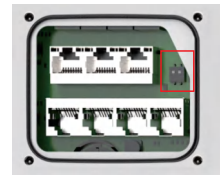

Procedure:

Step 1. Select Parallel setting

Step 2. Set the master ID to 1

Step 3. Set the Salver ID to 2,3,4and so on....

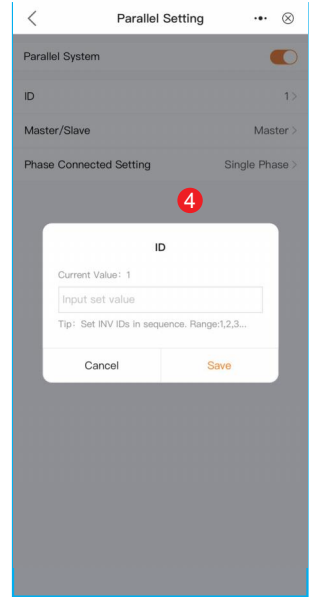
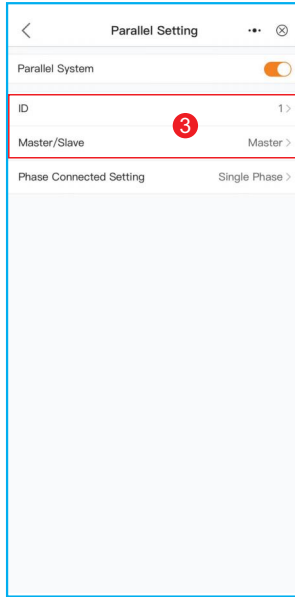
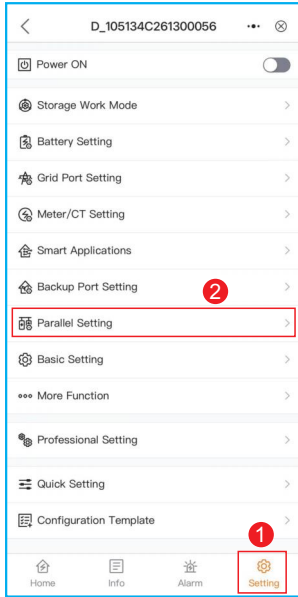

NOTE:

When under parallel system (inverter amount > 2), the AC cable length difference from inverter grid/backport to the busbar should not exceed 10%.



NOTE:

If the inverter amount ≥ 2 in parallel mode on site, you must set the parallel mode on Solis app for each inverter in case of avoiding the damage to inverter when power on, the specific setting method can refer to the chapter.



NOTE:

Except the battery settings, all the operation parameters can be synchronized by the master inverter to all the slave inverters. The battery settings need to be set up separately because each inverter might have different battery conditions.

Message Name	Information Description	Troubleshooting Suggestion
Off	Control device to shutdown	1. Turn on the device in the ON/OFF Setting.
LmtByEPM	The device's output is under controlled	<ol style="list-style-type: none"> 1. Confirm whether the inverter is connected to an external EPM/meter to prevent reverse current. 2. Confirm whether the inverter is controlled by an external third-party device. 3. Confirm whether the power setting of the inverter power control is limited. 4. Verify settings in section 6.6.7 and check your meter readings.
LmtByDRM	DRM Function ON	1. No need to deal with it.
LmtByTemp	Over temperature power limited	1. No need to deal with it, the device is in normal operation.
LmtByFreq	Frequency power limited	
LmtByVg	The device is in the Volt-Watt mode	<ol style="list-style-type: none"> 1. Due to the requirements of local safety regulations, when the grid voltage is high, the Volt-watt working mode is triggered, which generally does not need to be dealt with. 2. Inverter factory test errors causing this mode to open, if you need to close, you can close this mode in LCD, set the process: Main menu → Advanced Settings → Password 0010 → STD mode settings → Working Mode → Working mode: NULL → Save and exit.
LmtByVar	The device is in the Volt-Var mode of operation	<ol style="list-style-type: none"> 1. Due to the requirements of local safety regulations, when the grid voltage is high, the Volt-watt working mode is triggered, which generally does not need to be dealt with. 2. Inverter factory test errors causing this mode to open, if you need to close, you can close this mode in LCD, set the process: Main menu → Advanced Settings → Password 0010 → STD mode settings → Working Mode → Working mode: NULL → Save and exit.
LmtByUnFr	Under frequency limit	1. No need to deal with it.
Standby	Bypass run	
StandbySynoch	Off grid status to On grid status	
GridToLoad	Grid to load	

8. Troubleshooting

Message Name	Information Description	Troubleshooting Suggestion
Surge Alarm	On-site grid surge	<ol style="list-style-type: none"> 1. Grid side fault, restart the device. If it is still not eliminated, please contact the manufacturer's customer service.
OV-G-V01	Grid voltage exceeds the upper voltage range	<ol style="list-style-type: none"> 1. Confirm whether the power grid is abnormal. 2. Confirm that the AC cable is properly connected. 3. Restart the system and check if the fault persists.
UN-G-V01	Grid voltage exceeds the lower voltage range	
OV-G-F01	Grid frequency exceeds the upper frequency range	
UN-G-F01	Grid frequency exceeds the lower frequency range	
G-PHASE	Unbalanced grid voltage	
G-F-GLU	Grid voltage frequency fluctuation	
NO-Grid	No grid	
OV-G-V02	Grid transient overvoltage	
OV-G-V03	Grid transient overvoltage	<ol style="list-style-type: none"> 1. Restart the system, confirm if that the fault continues.
IGFOL-F	Grid current tracking failure	<ol style="list-style-type: none"> 1. Confirm whether the power grid is abnormal. 2. Confirm that the AC cable is properly connected. 3. Restart the system and check if the fault persists.
OV-G-V05	Grid voltage RMS instantaneous overvoltage fault	
OV-G-V04	Grid voltage exceeds the upper voltage range	
UN-G-V02	Grid voltage exceeds the lower voltage range	
OV-G-F02	Grid frequency exceeds the upper frequency range	
UN-G-F02	Grid frequency exceeds the lower frequency range	
NO-Battery	Battery is not connected	<ol style="list-style-type: none"> 1. Check on information page 1 – Verify the battery voltage is within standards. 2. Measure battery voltage at plug.
OV-Vbackup	Inverting overvoltage	<ol style="list-style-type: none"> 1. Check whether the backup port wiring is normal 2. Restart the system, confirm that the fault continues.
Over-Load	Load overload fault	<ol style="list-style-type: none"> 1. Backup load power is too large, or some inductive load startup power is too large, need to remove some backup load, or remove the inductive load on the backup.

8. Troubleshooting

Message Name	Information Description	Troubleshooting Suggestion
BatName-FAIL	Wrong battery brand selection	1. Confirm whether the battery model selection is consistent with the actual one.
CAN Fail	CAN Fail	1. Can failure is a failure of communication between inverter and battery. Check cable conditions. Check to ensure you have it plugged in on the CAN port of the battery and inverter. Check that you are using the right cable. Some batteries require a special battery from the battery manufacturer.
OV-Vbatt	Battery overvoltage detected	1. Verify battery voltage is within standards. Measure battery voltage at inverter connection point. Contact your battery manufacturer for further service.
UN-Vbatt	Battery undervoltage detected	1. Restart the system and check if the fault persists. If it is still not eliminated, please contact the manufacturer's customer service.
Fan Alarm	Fan alarm	1. Check if the internal fan is working correctly or jammed.
OV-DC01 (1020 DATA:0001)	DC 1 input overvoltage	1. Check if the PV voltage is abnormal 2. Restart the system, confirm that the fault continues
OV-DC02 (1020 DATA:0002)	DC 2 input overvoltage	
OV-BUS (1021 DATA:0000)	DC bus overvoltage	1. Restart the system, confirm that the fault continues.
UN-BUS01 (1023 DATA:0001)	DC bus undervoltage	
UNB-BUS (1022 DATA:0000)	DC bus unbalanced voltage	
UN-BUS02 (1023 DATA:0002)	Abnormal detection of DC bus voltage	
DC-INTF. (1027 DATA:0000)	DC hardware overcurrent (1, 2, 3, 4)	1. Check if the DC wires are connected correctly without loose connection.
OV-G-I (1018 DATA:0000)	A phase RMS value overcurrent	1. Confirm that the grid is abnormal. 2. Confirm that the AC cable connection is not abnormal. 3. Restart the system, confirm that the fault continues.
OV-DCA-I (1025 DATA:0000)	DC 1 average overcurrent	1. Restart the system, confirm that the fault continues.
OV-DCB-I (1026 DATA:0000)	DC 2 average overcurrent	
GRID-INTF. (1030 DATA:0000)	AC hardware overcurrent (abc phase)	

8. Troubleshooting

Message Name	Information Description	Troubleshooting Suggestion
DCInj-FAULT (1037 DATA:0000)	The current DC component exceeds the limit	<ol style="list-style-type: none"> 1. Confirm that the grid is abnormal. 2. Confirm that the AC cable connection is not abnormal. 3. Restart the system, confirm that the fault continues.
IGBT-OV-I (1048 DATA:0000)	IGBT overcurrent	<ol style="list-style-type: none"> 1. Restart the system, confirm that the fault continues.
OV-TEM (1032 DATA:0000)	Module over temperature	<ol style="list-style-type: none"> 1. Check whether the surrounding environment of the inverter has poor heat dissipation. 2. Confirm whether the product installation meets the requirements.
RelayChk-FAIL (1035 DATA:0000)	Relay failure	<ol style="list-style-type: none"> 1. Restart the system, confirm that the fault continues.
UN-TEM (103A DATA:0000)	Low temperature protection	<ol style="list-style-type: none"> 1. Check the working environment temperature of the inverter. 2. Restart the system to confirm if the fault continues.
PV ISO-PRO01 (1033 DATA:0001)	PV negative ground fault	<ol style="list-style-type: none"> 1. Check whether the PV strings have insulation problems. 2. Check whether the PV cable is damaged.
PV ISO-PRO02 (1033 DATA:0002)	PV positive ground fault	
12Power-FAULT (1038 DATA:0000)	12V undervoltage failure	<ol style="list-style-type: none"> 1. Check current leakage to ground. Verify your grounding. Verify all wires are in good condition and not leaking current to ground.
ILeak-PRO01 (1034 DATA:0001)	Leakage current failure 01 (30mA)	
ILeak-PRO02 (1034 DATA:0002)	Leakage current failure 02 (60mA)	
ILeak-PRO03 (1034 DATA:0003)	Leakage current failure 03 (150mA)	
ILeak-PRO04 (1034 DATA:0004)	Leakage current failure 04	
ILeak_Check (1039 DATA:0000)	Leakage current sensor failure	
GRID-INTF02 (1046 DATA:0000)	Power grid disturbance 02	<ol style="list-style-type: none"> 1. Confirm whether the grid is seriously distorted. 2. Check whether the AC cable is connected reliably.
OV-Vbatt-H/ OV-BUS-H (1051 DATA:0000)	Battery overvoltage hardware failure / VBUS	<ol style="list-style-type: none"> 1. Check if the battery circuit breaker is tripping. 2. Check if the battery is damaged.

Message Name	Information Description	Troubleshooting Suggestion
OV-ILLC (1052 DATA:0000)	LLC hardware overcurrent	1. Check whether the backup load is overloaded. 2. Restart the system, confirm that the fault continues.
INI-FAULT (1031 DATA:0000)	AD zero drift overlink	1. Restart the system, confirm that the fault continues.
DSP-B-FAULT (1036 DATA:0000)	The master-slave DSP communication is abnormal	
AFCI-Check (1040 DATA:0000)	AFCI self-test failure	
ARC- FAULT (1041 DATA:0000)	AFCI failure	1. Verify connections are tight within your PV system. Arc fault settings can be changed in advanced settings if further adjustment is necessary.

Table 8.1 Fault message and description



NOTE:

If the inverter displays any alarm message as listed in Table 8.1; please turn off the inverter and wait for 5 minutes before restarting it .
If the failure persists, please contact your local distributor or the service center.

Please keep ready with you the following information before contacting us.

1. Serial number of Solis three phase inverter;
2. The distributor/dealer of Solis three phase inverter (if available);
3. Installation date.
4. The description of the problem together with necessary information, pictures, attachment.
5. The PV array configuration (e.g. number of panels, capacity of panels, number of strings, etc.);
6. Your contact details.

9. Specifications

Technical Data	S6-EH3P60K10-LV-YD-H	S6-EH3P75K10-LV-YD-H
Input DC (PV side)		
Recommended max. PV array size	120kW	150kW
Max. usable PV input power	120kW	150kW
Max. input voltage	1000V	
Rated voltage	600V	
Start-up voltage	180V	
MPPT voltage range	150-950V	
Max. input current	10*42A	
Max. short circuit current	10*60A	
MPPT number/Max input strings number	10/20	
Battery		
Battery Type	Li-ion	
Battery Voltage range	300 - 950V	
Maximum charge / discharge current	100A*2 /100A*2	
Number of battery port	2	
Maximum charge / discharge current of each port	100A	
Communication	CAN/RS485	
Output AC(Back-up)		
Rated output power	60kW	75kW
Max. apparent output power	1.6 times of rated power, 10s 2 times of rated power, 200ms	1.4 times of rated power, 10s 1.6 times of rated power, 200ms
Back-up switch time	<10ms	
Rated output voltage	3/(N)/PE, 127V / 220V 3/(N)/PE, 133V / 230V	
Rated frequency	50 Hz/60 Hz	
THDv(@linear load)	<3%	
Input AC (Grid side)		
Max. input current	250A	

9. Specifications

Technical Data	S6-EH3P60K10-LV-YD-H	S6-EH3P75K10-LV-YD-H
Input AC (Generator)		
Max. input power	60kW	75kW
Rated input current	157.5A/150.6A	196.8A/188.2A
Rated input voltage	3/(N)/PE, 127V / 220V 3/(N)/PE, 133V / 230V	
Rated input frequency	50Hz/60Hz	
Output AC(Grid side)		
Rated output power	60kW	75kW
Max. apparent output power	60kVA	75kVA
Rated grid voltage	3/(N)/PE, 127V / 220V 3/(N)/PE, 133V / 230V	
Rated grid frequency	50Hz/60Hz	
Rated grid output current	157.5A/150.6A	196.8A/188.2A
Power Factor	> 0.99 (0.8 leading - 0.8 lagging)	
THDi	<3%	
Efficiency		
Max. efficiency	96.0%	
EU efficiency	94.5%	94.6%
Battery charged efficiency	95.6%	
Battery discharged efficiency	95.6%	
Protection		
Anti-islanding protection	Yes	
Insulation Resistor detection	Yes	
Output over current protection	Yes	
Output short protection	Yes	
Output over voltage protection	Yes	
DC switch	Yes	
DC reverse polarity protection	Yes	
Protection class / Over voltage category	I/ DC II, AC III	
Surge protection	DC Type II/AC Type II	
Integrated AFCI 2.0	Optional	

9. Specifications

Technical Data	S6-EH3P60K10-LV-YD-H	S6-EH3P75K10-LV-YD-H
General data		
Max. allowable phase imbalance (grid & back-up)	100%	
Max. power per phase (grid & back-up)	20kW	25kW
Dimensions(W/H/D)	1174*814*400mm	
Weight	170kg	
Topology	Transformerless	
Operation temperature range	-25°C ~ +60°C	
Relative humidity	0-100%	
Ingress protection	IP66	
Noise emission (typical)	<70 dB(A)	
Cooling concept	Intelligent redundant fan-cooling	
Max.operation altitude	3000m	
Grid connection standard	G99, VDE-AR-N 4105 / VDE V 0124, EN 50549-1&2/ EN 50549-10, VDE 0126 / UTE C 15/VFR:2019, NTS 631/RD 1699/RD 244 / UNE 206006 / UNE 206007-1, CEI 0-21, C10/11, NRS 097-2-1, TOR, EIFS 2018.2, IEC 62116, IEC 61727, IEC 60068, IEC 61683, EN 50530, MEA, PEA,PORTARIA N° 140, DE 21 DE MARÇO DE 2022	
Safty/EMC standard	IEC/EN 62109-1/-2, IEC/EN 61000-6-2/-4, EN 55011	
Features		
PV connection	MC4 Quick connection plug	
Battery connection	Terminal connector	
AC connection	Terminal Block	
Display	7.0" LCD display & Bluetooth + APP	
Communication	CAN, RS485-115200, Ethernet, optional:Wi-Fi, cellular, LAN	
Warranty	5 years (Extendable to 20 years)	

9. Specifications

Technical Data	S6-EH3P80K10-NV-YD-H	S6-EH3P99.9K10-NV-YD-H
Input DC (PV side)		
Recommended max. PV array size	160kW	200kW
Max. usable PV input power	160kW	200kW
Max. input voltage	1000V	
Rated voltage	600V	
Start-up voltage	180V	
MPPT voltage range	150-950V	
Max. input current	10*42A	
Max. short circuit current	10*60A	
MPPT number/Max input strings number	10/20	
Battery		
Battery Type	Li-ion	
Battery Voltage range	300 - 950V	
Maximum charge / discharge current	100A*2 /100A*2	
Number of battery port	2	
Maximum charge / discharge current of each port	100A	
Communication	CAN/RS485	
Output AC(Back-up)		
Rated output power	80kW	99.9kW
Max. apparent output power	1.6 times of rated power, 10s 2 times of rated power, 200ms	
Back-up switch time	<10ms	
Rated output voltage	3/N/PE, 220V/380 V 3/N/PE, 230V/400 V	
Rated frequency	50 Hz/60 Hz	
THDv(@linear load)	<3%	
Input AC (Grid side)		
Max. input current	250A	

9. Specifications

Technical Data	S6-EH3P80K10-NV-YD-H	S6-EH3P99.9K10-NV-YD-H
Input AC (Generator)		
Max. input power	80kW	99.9kW
Rated input current	121.6A/115.5A	151.8A/144.2A
Rated input voltage	3/N/PE, 220V/380 V 3/N/PE, 230V/400 V	
Rated input frequency	50Hz/60Hz	
Output AC(Grid side)		
Rated output power	80kW	99.9kW
Max. apparent output power	80kVA	99.9kVA
Rated grid voltage	3/N/PE, 220V/380 V 3/N/PE, 230V/400 V	
Rated grid frequency	50Hz/60Hz	
Rated grid output current	121.6A/115.5A	151.8A/144.2A
Power Factor	> 0.99 (0.8 leading - 0.8 lagging)	
THDi	<3%	
Efficiency		
Max. efficiency	97.5%	
EU efficiency	96.9%	97.1%
Battery charged efficiency	97.0%	
Battery discharged efficiency	97.0%	
Protection		
Anti-islanding protection	Yes	
Insulation Resistor detection	Yes	
Output over current protection	Yes	
Output short protection	Yes	
Output over voltage protection	Yes	
DC switch	Yes	
DC reverse polarity protection	Yes	
Protection class / Over voltage category	I/ DC II, AC III	
Surge protection	DC Type II/AC Type II	
Integrated AFCI 2.0	Optional	

9. Specifications

Technical Data	S6-EH3P80K10-NV-YD-H	S6-EH3P99.9K10-NV-YD-H
General data		
Max. allowable phase imbalance (grid & back-up)	100%	
Max. power per phase (grid & back-up)	26.66kW	33.3kW
Dimensions(W/H/D)	1174*814*400mm	
Weight	170kg	
Topology	Transformerless	
Operation temperature range	-25°C ~ +60°C	
Relative humidity	0-100%	
Ingress protection	IP66	
Noise emission (typical)	<70 dB(A)	
Cooling concept	Intelligent redundant fan-cooling	
Max.operation altitude	3000m	
Grid connection standard	G99, VDE-AR-N 4105 / VDE V 0124, EN 50549-1&2/ EN 50549-10, VDE 0126 / UTE C 15/VFR:2019, NTS 631/RD 1699/RD 244 / UNE 206006 / UNE 206007-1, CEI 0-21, C10/11, NRS 097-2-1, TOR, EIFS 2018.2, IEC 62116, IEC 61727, IEC 60068, IEC 61683, EN 50530, MEA, PEA,PORTARIA N° 140, DE 21 DE MARÇO DE 2022	
Safty/EMC standard	IEC/EN 62109-1/-2, IEC/EN 61000-6-2/-4, EN 55011	
Features		
PV connection	MC4 Quick connection plug	
Battery connection	Terminal connector	
AC connection	Terminal Block	
Display	7.0" LCD display & Bluetooth + APP	
Communication	CAN, RS485-115200, Ethernet, optional:Wi-Fi, cellular, LAN	
Warranty	5 years (Extendable to 20 years)	

9. Specifications

Technical Data	S6-EH3P100K10-NV-YD-H	S6-EH3P125K10-NV-YD-H
Input DC (PV side)		
Recommended max. PV array size	200kW	250kW
Max. usable PV input power	200kW	250kW
Max. input voltage	1000V	
Rated voltage	600V	
Start-up voltage	180V	
MPPT voltage range	150-950V	
Max. input current	10*42A	
Max. short circuit current	10*60A	
MPPT number/Max input strings number	10/20	
Battery		
Battery Type	Li-ion	
Battery Voltage range	300 - 950V	
Maximum charge / discharge current	100A*2 /100A*2	
Number of battery port	2	
Maximum charge / discharge current of each port	100A	
Communication	CAN/RS485	
Output AC(Back-up)		
Rated output power	100kW	125kW
Max. apparent output power	1.6 times of rated power, 10s 2 times of rated power, 200ms	1.4 times of rated power, 10s 1.6 times of rated power, 200ms
Back-up switch time	<10ms	
Rated output voltage	3/N/PE, 220V/380 V 3/N/PE, 230V/400 V	
Rated frequency	50 Hz/60 Hz	
THDv(@linear load)	<3%	
Input AC (Grid side)		
Max. input current	250A	

9. Specifications

Technical Data	S6-EH3P100K10-NV-YD-H	S6-EH3P125K10-NV-YD-H
Input AC (Generator)		
Max. input power	100kW	125kW
Rated input current	151.9A/144.3A	189.9A/180.4A
Rated input voltage	3/N/PE, 220V/380 V 3/N/PE, 230V/400 V	
Rated input frequency	50Hz/60Hz	
Output AC(Grid side)		
Rated output power	100kW	125kW
Max. apparent output power	100kVA	125kVA
Rated grid voltage	3/N/PE, 220V/380 V 3/N/PE, 230V/400 V	
Rated grid frequency	50Hz/60Hz	
Rated grid output current	151.9A/144.3A	189.9A/180.4A
Power Factor	> 0.99 (0.8 leading - 0.8 lagging)	
THDi	<3%	
Efficiency		
Max. efficiency	97.5%	
EU efficiency	97.1%	97.2%
Battery charged efficiency	97.0%	
Battery discharged efficiency	97.0%	
Protection		
Anti-islanding protection	Yes	
Insulation Resistor detection	Yes	
Output over current protection	Yes	
Output short protection	Yes	
Output over voltage protection	Yes	
DC switch	Yes	
DC reverse polarity protection	Yes	
Protection class / Over voltage category	I/ DC II, AC III	
Surge protection	DC Type II/AC Type II	
Integrated AFCI 2.0	Optional	

9. Specifications

Technical Data	S6-EH3P100K10-NV-YD-H	S6-EH3P125K10-NV-YD-H
General data		
Max. allowable phase imbalance (grid & back-up)	100%	
Max. power per phase (grid & back-up)	33.33kW	41.66kW
Dimensions(W/H/D)	1174*814*400mm	
Weight	170kg	
Topology	Transformerless	
Operation temperature range	-25°C ~ +60°C	
Relative humidity	0-100%	
Ingress protection	IP66	
Noise emission (typical)	<70 dB(A)	
Cooling concept	Intelligent redundant fan-cooling	
Max.operation altitude	3000m	
Grid connection standard	G99, VDE-AR-N 4105 / VDE V 0124, EN 50549-1&2/ EN 50549-10, VDE 0126 / UTE C 15/VFR:2019, NTS 631/RD 1699/RD 244 / UNE 206006 / UNE 206007-1, CEI 0-21, C10/11, NRS 097-2-1, TOR, EIFS 2018.2, IEC 62116, IEC 61727, IEC 60068, IEC 61683, EN 50530, MEA, PEA,PORTARIA N° 140, DE 21 DE MARÇO DE 2022	
Safty/EMC standard	IEC/EN 62109-1/-2, IEC/EN 61000-6-2/-4, EN 55011	
Features		
PV connection	MC4 Quick connection plug	
Battery connection	Terminal connector	
AC connection	Terminal Block	
Display	7.0" LCD display & Bluetooth + APP	
Communication	CAN, RS485-115200, Ethernet, optional:Wi-Fi, cellular, LAN	
Warranty	5 years (Extendable to 20 years)	

9. Specifications

Technical Data	S6-EH3P75K10-NV-YD-H
Input DC (PV side)	
Recommended max. PV array size	150kW
Max. usable PV input power	150kW
Max. input voltage	1000V
Rated voltage	600V
Start-up voltage	180V
MPPT voltage range	150-950V
Max. input current	10*42A
Max. short circuit current	10*60A
MPPT number/Max input strings number	10/20
Battery	
Battery Type	Li-ion
Battery Voltage range	300 - 950V
Maximum charge / discharge current	100A*2 /100A*2
Number of battery port	2
Maximum charge / discharge current of each port	100A
Communication	CAN/RS485
Output AC(Back-up)	
Rated output power	75kW
Max. apparent output power	1.6 times of rated power, 10s 2 times of rated power, 200ms
Back-up switch time	< 10ms
Rated output voltage	3/N/PE, 220V/380 V
Rated frequency	60 Hz
THDv(@linear load)	<3%
Input AC (Grid side)	
Max. input current	250A

9. Specifications

Technical Data	S6-EH3P75K10-NV-YD-H
Input AC (Generator)	
Max. input power	75kW
Rated input current	114.0A
Rated input voltage	3/N/PE, 220V/380 V
Rated input frequency	60Hz
Output AC(Grid side)	
Rated output power	75kW
Max. apparent output power	75kVA
Rated grid voltage	3/N/PE, 220V/380 V
Rated grid frequency	60Hz
Rated grid output current	114.0A
Power Factor	> 0.99 (0.8 leading - 0.8 lagging)
THDi	<3%
Efficiency	
Max. efficiency	97.5%
EU efficiency	96.9%
Battery charged efficiency	97.0%
Battery discharged efficiency	97.0%
Protection	
Anti-islanding protection	Yes
Insulation Resistor detection	Yes
Output over current protection	Yes
Output short protection	Yes
Output over voltage protection	Yes
DC switch	Yes
DC reverse polarity protection	Yes
Protection class / Over voltage category	I/ DC II, AC III
Surge protection	DC Type II/AC Type II
Integrated AFCI 2.0	Optional

9. Specifications

Technical Data	S6-EH3P75K10-NV-YD-H
General data	
Max. allowable phase imbalance (grid & back-up)	100%
Max. power per phase (grid & back-up)	25kW
Dimensions(W/H/D)	1174*814*400mm
Weight	170kg
Topology	Transformerless
Operation temperature range	-25°C ~ +60°C
Relative humidity	0-100%
Ingress protection	IP66
Noise emission (typical)	<70 dB(A)
Cooling concept	Intelligent redundant fan-cooling
Max.operation altitude	3000m
Grid connection standard	ORDINANCE (PORTARIA) NO.140 ORDINANCE NO. 515
Safty/EMC standard	IEC/EN 62109-1/-2, IEC/EN 61000-6-2/-4, EN 55011
Features	
PV connection	MC4 Quick connection plug
Battery connection	Terminal connector
AC connection	Terminal Block
Display	7.0" LCD display & Bluetooth + APP
Communication	CAN, RS485-115200, Ethernet, optional:Wi-Fi, cellular, LAN
Warranty	5 years (Extendable to 20 years)

9. Specifications

Technical Data	S6-EH3P75K10-NV-YD-H-PRO
Input DC (PV side)	
Recommended max. PV array size	250kW
Max. usable PV input power	250kW
Max. input voltage	1000V
Rated voltage	600V
Start-up voltage	180V
MPPT voltage range	150-950V
Max. input current	10*42A
Max. short circuit current	10*60A
MPPT number/Max input strings number	10/20
Battery	
Battery Type	Li-ion
Battery Voltage range	300 - 950V
Maximum charge / discharge current	100A*2 /100A*2
Number of battery port	2
Maximum charge / discharge current of each port	100A
Communication	CAN/RS485
Output AC(Back-up)	
Rated output power	125kW
Max. apparent output power	1.4 times of rated power, 10s 1.6 times of rated power, 200ms
Back-up switch time	< 10ms
Rated output voltage	3/N/PE, 220V/380 V
Rated frequency	60 Hz
THDv(@linear load)	<3%
Input AC (Grid side)	
Max. input current	114A

9. Specifications

Technical Data	S6-EH3P75K10-NV-YD-H-PRO
Input AC (Generator)	
Max. input power	125kW
Rated input current	189.9A
Rated input voltage	3/N/PE, 220V/380 V
Rated input frequency	60Hz
Output AC(Grid side)	
Rated output power	75kW
Max. apparent output power	75kVA
Rated grid voltage	3/N/PE, 220V/380 V
Rated grid frequency	60Hz
Rated grid output current	114.0A
Power Factor	>0.99 (0.8 leading - 0.8 lagging)
THDi	<3%
Efficiency	
Max. efficiency	97.5%
EU efficiency	97.2%
Battery charged efficiency	97.0%
Battery discharged efficiency	97.0%
Protection	
Anti-islanding protection	Yes
Insulation Resistor detection	Yes
Output over current protection	Yes
Output short protection	Yes
Output over voltage protection	Yes
DC switch	Yes
DC reverse polarity protection	Yes
Protection class / Over voltage category	I/ DC II, AC III
Surge protection	DC Type II/AC Type II
Integrated AFCI 2.0	Yes

9. Specifications

Technical Data	S6-EH3P75K10-NV-YD-H-PRO
General data	
Max. allowable phase imbalance (grid & back-up)	100%
Max. power per phase (grid & back-up)	25kW
Dimensions(W/H/D)	1174*814*400mm
Weight	170kg
Topology	Transformerless
Operation temperature range	-25°C ~ +60°C
Relative humidity	0-100%
Ingress protection	IP66
Noise emission (typical)	<70 dB(A)
Cooling concept	Intelligent redundant fan-cooling
Max.operation altitude	3000m
Grid connection standard	ORDINANCE (PORTARIA) NO.140 ORDINANCE NO. 515
Safty/EMC standard	IEC/EN 62109-1/-2, IEC/EN 61000-6-2/-4, EN 55011
Features	
PV connection	MC4 Quick connection plug
Battery connection	Terminal connector
AC connection	Terminal Block
Display	7.0" LCD display & Bluetooth + APP
Communication	Standard: WIFI+LAN+Bluetooth, CAN-BMS*2, CAN-Parallel*2, LAN, RS485-Meter, Rs485, DRM, DI* 5, DO*4 Optional: 4G
Warranty	5 years (Extendable to 20 years)

Frequently Asked Questions

Q1: Why I have "CAN Fail" Alarm on the inverter?

A: "CAN Fail" indicates the CAN communication between inverter and battery is lost. Please double check if your CAN cable is correctly connected and if your battery is power on.

Q2: Why I have "BATName-Fail" Alarm on the inverter ?

A: Please check in the "Battery Setting->Battery Model" setting and confirm you selected the correct battery option as the nameplate of your battery module.

Q3: Why I have "MET-SLT-Fail" Alarm on the inverter?

A: Please check in the "Meter Setting->Meter Type" setting and confirm you selected the correct meter option corresponding to your smart meter.

Q4: Why the power values on the screen are fluctuating very fast?

A: If your loads are changing drastically, the inverter will adjust its power accordingly. If you confirm the loads are stable while the inverter power is changing very fast, please double check your meter CT's direction and make sure the arrow is towards grid.

Q5: Why I have "OV-ILLC" Alarm on the inverter ?

A: OV-ILLC indicates there is an overcurrent issue on the internal LLC circuit. It could be transient status during extreme condition such as overload. If it happens constantly or too frequent and the extreme conditions have been excluded, please contact Solis service team.

Q6: Why I have "OV-BATT-H" Alarm on the inverter ?

A: OV-BATT-H indicates over voltage issue on the hardware of battery circuit. It could be caused by high battery voltage at full SOC, battery suddenly switching off, etc. If it happens constantly or too frequent and the extreme conditions have been excluded, please contact Solis service team.

Q7: Why I have "No-Battery" Alarm on the inverter?

A: Please double check if the battery power cables have been correctly connected and the battery breaker (on battery or external) has been turn on. If you don't want to connect the battery for now, please select the "No battery" option in "Battery Setting->Battery Model" to prevent the alarm to show up.

Ginlong Technologies Co., Ltd.

No. 57 Jintong Road, Binhai Industrial Park, Xiangshan, Ningbo,
Zhejiang, 315712, P.R.China.

Tel: +86 (0)574 6578 1806

Email: info@ginlong.com

Web: www.solisinverters.com

Please adhere to the actual products in case of any discrepancies in this user manual.

If you encounter any problem on the inverter, please find out the inverter S/N and contact us, we will try to respond to your question ASAP.